

# Electrical Systems

## UNIT 3

### Objectives

---

After studying this unit, the student will:

1. Understand fundamentals of electricity.
2. Identify power distribution systems and equipment.
3. Be familiar with commonly used electrical material.
4. Recognize electrical symbols shown on electrical plans.
5. Be able to interpret electrical plans and specifications.
6. Acquire knowledge about the basic electrical systems common to most types of buildings.
7. Understand electrical estimating procedures.

### Introduction

---

It is important that project managers and superintendents have a basic understanding of the fundamentals of electricity and how electrical systems work. You don't have to be an electrician or electrical engineer to understand how electrical systems work or to understand what is being installed and why.

Like many fields electrical contracting is very broad and it is nearly impossible for an individual to know everything, even after a lifetime of working in the industry, about electrical construction. Changes in the industry do occur and new systems are continually on the horizon. However, the principles on which all electrical systems work and the basics of electricity stay the same, even as more sophisticated applications are developed and installed every day.



## Fundamentals of Electricity

In order to understand electrical systems and to confidently coordinate with your subcontractors, it is important that you have a working knowledge of the fundamentals of electricity.

For electricity to flow there needs to be a source, a load, and a completely closed path. Think about what happens when you “flip” on your bedroom light switch. The switch when in the off position opens the path and stops the source from being able to force the flow of electricity through the load (the lightbulb). When the switch is closed, it completes the path from the service panel located somewhere in your house that is energized by the local utility company, and current flows through the load (the lightbulb). This system is a simple electrical circuit.

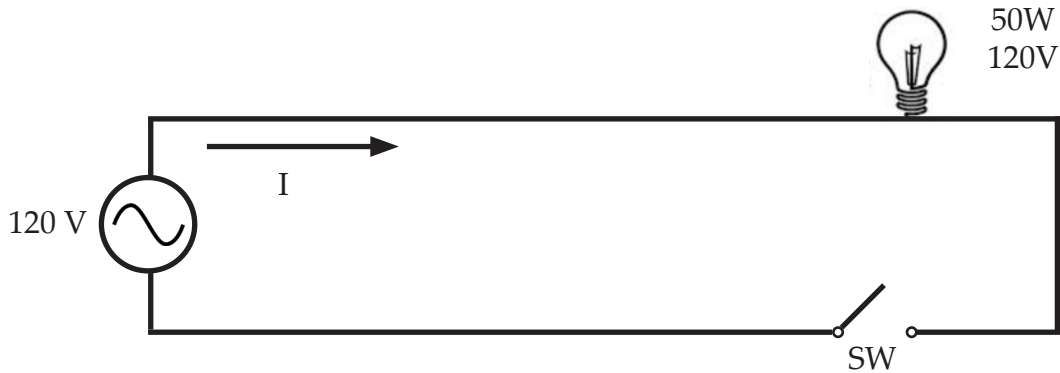

Figure 1A: Simple Circuit - Switch Open  
The Current (I) is zero  $I = 0$  Amps

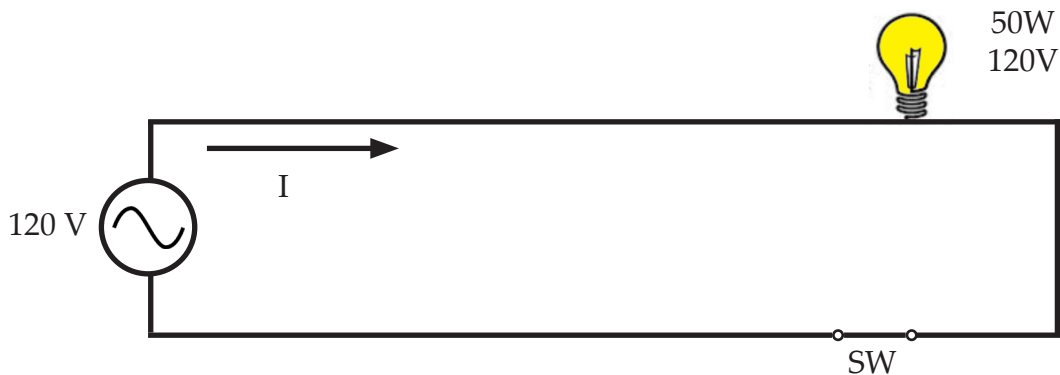

Figure 1B: Simple Circuit - Switch Closed  
The current (I) is calculated using the equation: Power = Current x Voltage (Watts Law) or  $P = I \times E$   
 $I = P / E = 50 \text{ Watts} \div 120 \text{ V} = 0.4167 \text{ Amps}$

## Circuits

A circuit is an arrangement of closed path(s) through which electricity (i.e., electrons) can travel. Most complete circuits include an energy source, conductors, insulators, loads, a switch or other control device, and a protective device (i.e., fuse).

A simple circuit consists of only one energy source, one conductor, and one load.

A series circuit has at least two loads. The conductor, loads, and control and protective devices are connected end-to-end to make up a single path through which electricity can travel from and back to the energy source. If a series circuit is interrupted at any point, electricity will not flow.

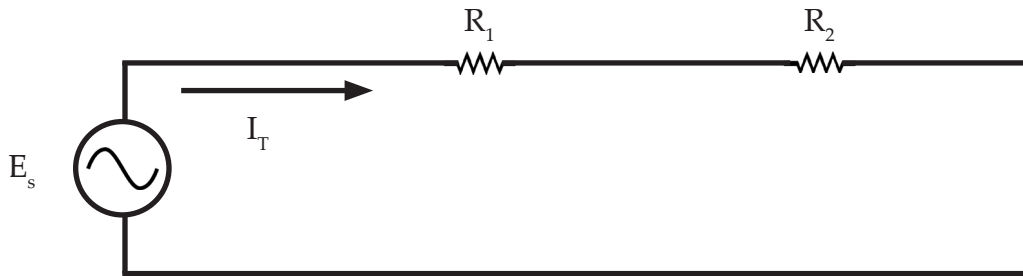

Figure 2: Series Circuit

A parallel circuit has two or more independent paths. If one path is interrupted, electricity can still flow through the remaining path(s).

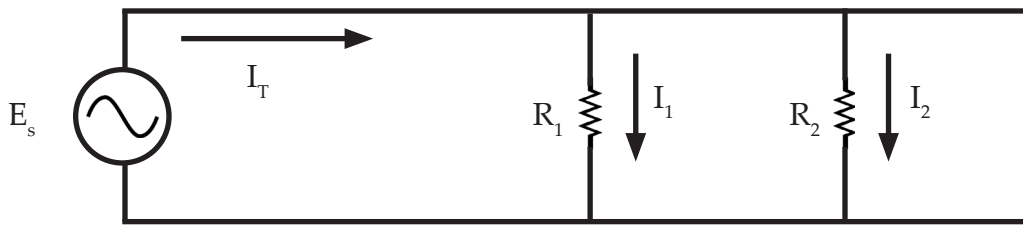

Figure 3: Parallel Circuit

A series – parallel circuit has a combination of a series path and two or more independent parallel paths. Depending on the arrangement of the loads and where a path interruption occurs the current may or may not continue to flow through the loads.

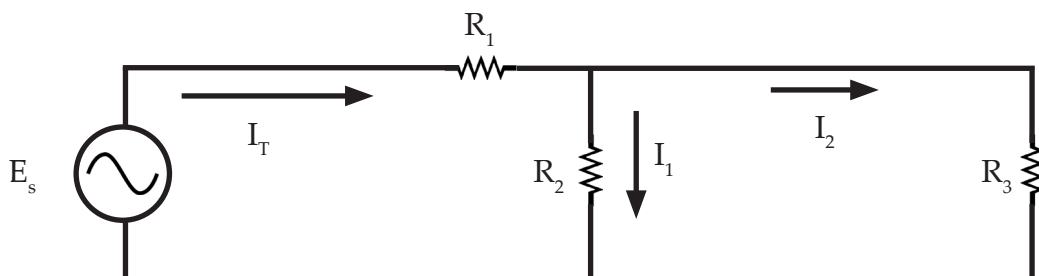

Figure 4: Series - Parallel Circuit

## Electrical Quantities

The basic quantities used to measure electricity are current, voltage, resistance, and power.

Current (I) is the rate at which electricity flows through a circuit. Current is measured in amperes or amps.

Voltage (E) also called “electromotive force” or “emf” is the force that causes electricity to flow. Voltage is measured in volts. In formulas, voltage is represented by either E or V. E will be used in this course.

Resistance (R) Most materials making up a circuit resist the flow of electricity. The amount of this resistance depends on the type of material and its dimensions. Resistance is measured in ohms. The symbol for ohms is the Greek letter Omega ( $\Omega$ ).

Power is the rate at which electrical energy is transformed; it is the rate of doing work and is measured in watts.

## Direct Current

Direct current (DC) is the constant flow of electricity through a conductor in one direction. A dry-cell battery connected to a light bulb is an example of a simple DC circuit.

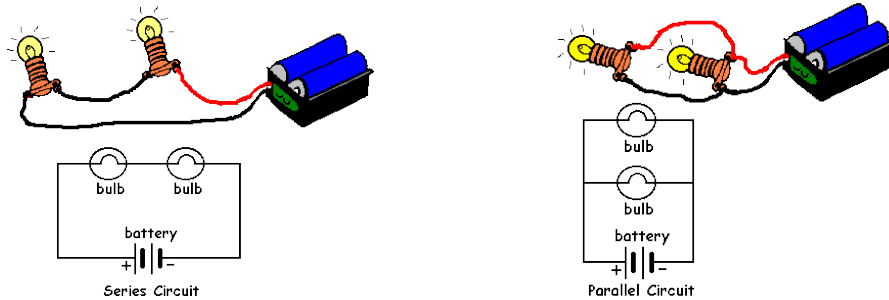

## Ohm's Law

Ohm's Law states the relationship between the current, voltage, and resistance of a simple DC circuit.

$$E = R \times I \quad R = E / I \quad \text{and} \quad I = E / R$$

where: I = current (intensity) in amps, A  
 E = voltage (electromotive force) in volts, V  
 R = resistance in ohms,  $\Omega$

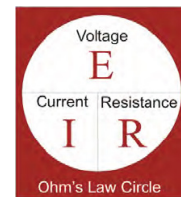

## Watt's Law

The basic form of Watt's Law states that the electrical power (P) in a simple dc circuit is the product of current and voltage.

$$P = I \times E \quad I = P / E \quad \text{and} \quad E = P / I$$

where: P = power in watts, W  
 I = current (intensity) in amps, A  
 E = voltage (electromotive force) in volts, V

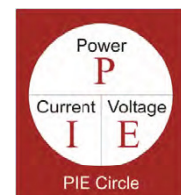



Two other important power formulas can be derived from Ohm's and Watt's Laws:

$$P = I^2 \times R$$

Derivation  $P = I \times E$  (Watt's Law) and  $E = I \times R$  (Ohm's Law). Since  $E = I \times R$ , substitute  $I \times R$  for  $E$  in the Watt's Law formula:  $P = I \times I \times R = I^2 \times R$ .

$$P = E^2 / R$$

Derivation  $P = I \times E$  (Watt's Law) and  $I = E/R$  (Ohm's Law). Since  $I = E/R$ , substitute  $E/R$  for  $I$  in the Watt's Law formula:  $P = E/R \times E = E^2 / R$ .

Ohm's Law and Watt's Law problems involving simple, series, or parallel circuits usually consist of calculating an unknown quantity (i.e., voltage) based on two or more known quantities (i.e. current, resistance, or power).

### Simple Circuits

The basic Ohm's Law and Watt's Law formulas can be applied directly to problems involving simple DC circuits.

PROBLEM: A simple DC circuit has a resistance of 3 ohms and a voltage of 12 volts.

- (a) What is the current?
- (b) What is the power rating?

- SOLUTION: (a)  $I = E / R = 12 \text{ volts} \div 3 \text{ ohms} = 4 \text{ amps}$
- (b)  $P = I \times E = 4 \text{ amps} \times 12 \text{ volts} = 48 \text{ watts}$

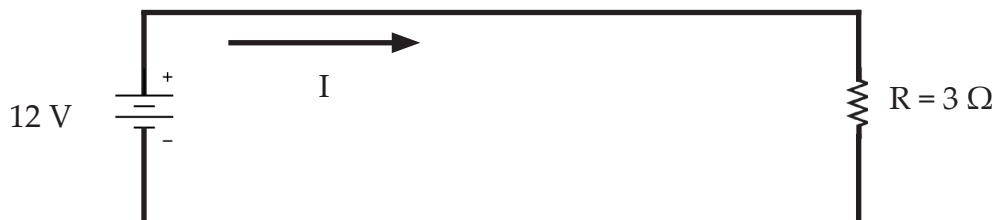

Figure 5: Simple DC Circuit

## DC Series Circuits

Four rules apply to DC series circuits:

- (1) The total voltage is the sum of the voltages across each load.
- (2) The current is the same in all parts of the circuit.
- (3) The total resistance is the sum of the individual load resistances.

$$R_{\text{total}} = R_1 + R_2 + R_3 \dots$$

- (4) The total power is the sum of the powers used by the individual loads.

PROBLEM: In the DC series circuit illustrated in Figure 6,  $I = 6$  amps,  $R_1 = 4$  ohms, and  $R_2 = 2$  ohms.

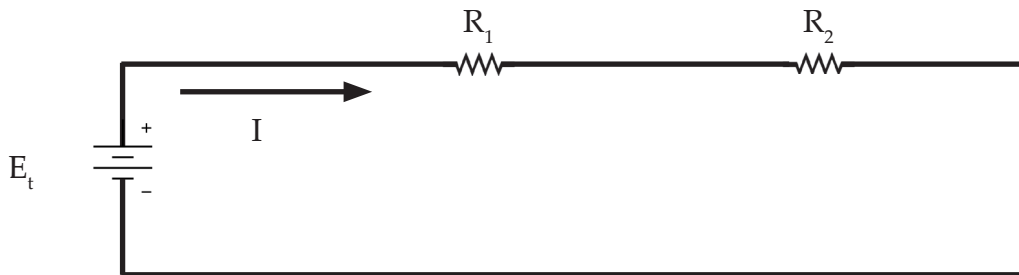

Figure 6: Series Circuit

- (a) What is the total resistance ( $R_t$ )?
- (b) What is the total voltage ( $E_t$ )?
- (c) What is the total power ( $P_t$ )?

SOLUTION: (a) Apply Rule 3 ( $R_t = R_1 + R_2$ ):

$$R_t = 4 \text{ ohms} + 2 \text{ ohms} = 6 \text{ ohms}$$

- (b) Apply Rule 1 ( $E_t = E_1 + E_2$ ) and Ohm's Law:

$$\begin{aligned} E_1 &= I \times R_1 = 6 \text{ amps} \times 4 \text{ ohms} = 24 \text{ volts} \\ E_2 &= I \times R_2 = 6 \text{ amps} \times 2 \text{ ohms} = \underline{+12 \text{ volts}} \\ E_t &= 36 \text{ volts} \end{aligned}$$

- (c) Apply Rule 4 ( $P_t = P_1 + P_2$ ) and Watt's Law:

$$\begin{aligned} P_1 &= I \times E_1 = 6 \text{ amps} \times 24 \text{ volts} = 144 \text{ watts} \\ P_2 &= I \times E_2 = 6 \text{ amps} \times 12 \text{ volts} = \underline{+72 \text{ watts}} \\ P_t &= 216 \text{ watts} \end{aligned}$$

## DC Parallel Circuits

The rules for DC parallel circuits are:

- (1) The voltage across each load is the same.
- (2) The total current is the sum of the currents in each load.
- (3) The total resistance is always lower than the smallest load resistance. The formula for calculating total resistance ( $R_t$ ) is:

$$\frac{1}{R_{\text{total}}} = \frac{1}{R_1} + \frac{1}{R_2} + \frac{1}{R_3} \dots$$

- (4) The total power is the sum of the powers used by the individual loads.

PROBLEM: In the DC parallel circuit illustrated in Figure 7,  $I = 3$  amps,  $R_1 = 4 \Omega$ , and  $R_2 = 1 \Omega$ .

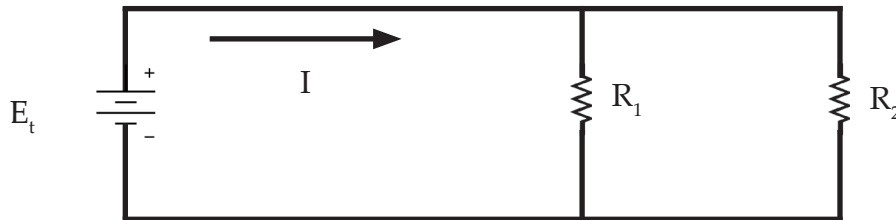

Figure 7: Parallel Circuit

- (a) What is the total resistance ( $R_t$ )?
- (b) What is the total voltage ( $E_t$ )?
- (c) What is the total power ( $P_t$ )?

SOLUTION: (a) Apply Rule 3 formula:

$$R_t = \frac{1}{\frac{1}{4} + \frac{1}{1}} = \frac{1}{\frac{5}{4}} = \frac{4}{5} = 0.8 \text{ ohm}$$

- (b) According to Rule 1, the voltage across each load is the same. Apply Ohm's Law just as you would to a problem involving a simple dc circuit where  $I = 3$  amps and  $R = 0.8$  ohm.

$$E_t = I \times R_t = 3 \text{ amps} \times 0.8 \text{ ohm} = 2.4 \text{ volts}$$

- (c) Apply Rule 4 ( $P_t = P_1 + P_2$ ) and the formula  $P = E^2 / R$

$$\begin{aligned} P_1 &= E^2 / R = 2.4^2 \text{ volts} / 4 \text{ ohms} = 1.44 \text{ watts} \\ P_2 &= E^2 / R = 2.4^2 \text{ volts} / 1 \text{ ohm} = +5.76 \text{ watts} \\ P_t &= 7.20 \text{ watts} \end{aligned}$$

## Alternating Current

Alternating current (AC) is the flow of electricity back and forth in a conductor at regular intervals. The rate of flow reversal is called "frequency". Nearly all AC power systems in the United States operate at a frequency of 60 cycles per second. This means that the electricity flows in one direction for 1/120 of a second and then in the other direction for 1/120 of a second. The current makes one complete cycle in 1/60 of a second or 60 complete cycles in one second.

The sine wave is commonly used to illustrate alternating current. The graph below shows the sine wave for a single-phase (1 $\phi$ ) AC current. The complete AC cycle is divided into two half cycles - - the first is given a positive value and the second a negative value. The first half cycle (+) begins at zero and rises to a peak value before returning to zero, at which point the second half cycle (-) peaks and returns to zero again.

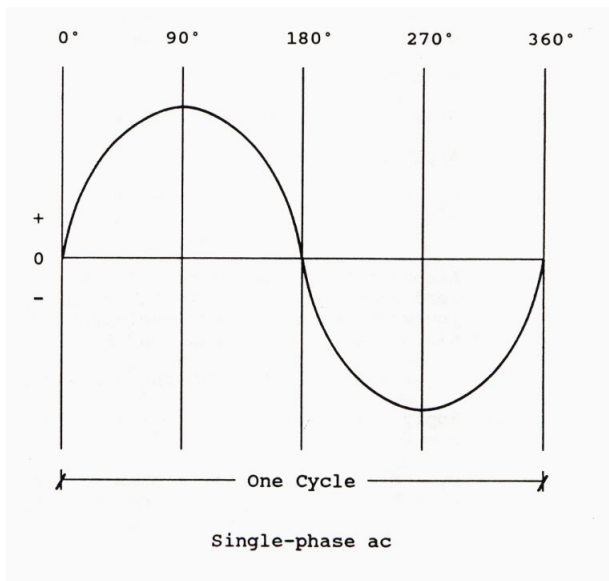

The disadvantage of single-phase AC is that the electrical power is cut off each time the current reaches "0". This problem can be avoided with three-phase (3 $\phi$ ) ac systems that provides overlapping cycles. The power supplied to a motor or other device is never cut off because when one phase reaches "0", the other two phases are either positive or negative.

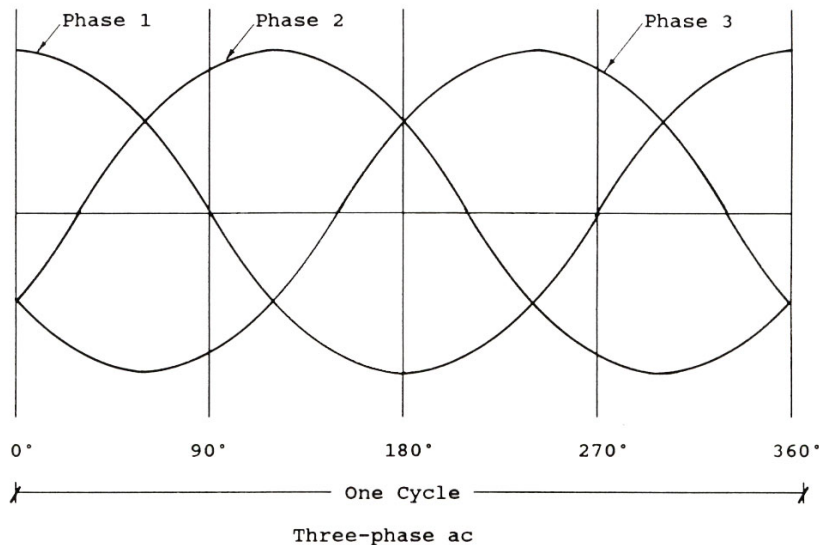

## In-Phase AC Circuits

The voltage and current of an AC circuit can be depicted on the same graph as separate sine waves. When the voltage and current begin and peak at exactly the same time, they are said to be "in phase". For all practical purposes, the "in phase" circuit consists of only resistance, the loads being devices such as light bulbs, toasters, or heaters.

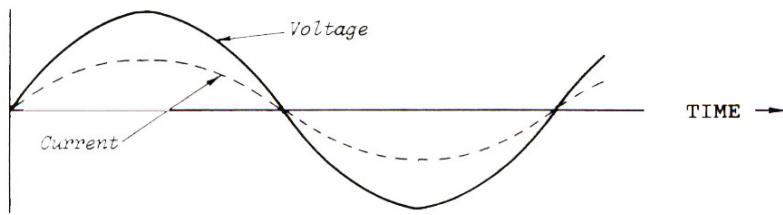

Voltage and current are in phase.

## Reactance and Out-of-Phase AC Circuits

A circuit can be put "out of phase" by inductive or capacitive reactance. "Reactance" is the term used to describe opposition to voltage and current caused by capacitors and inductors.

A simple capacitor consists of two conductor plates separated by a dielectric (insulator). Each plate stores energy in the form of electric charges when electricity flows through the capacitor. One plate becomes positively charged and the other negatively charged. The opposite charges on the plates produce a voltage in the capacitor that opposes changes in the circuit voltage.

Because changes in the circuit voltage are opposed by capacitive reactance, the peak of the current wave occurs ahead of the peak of the voltage wave. In other words, "Current leads voltage".

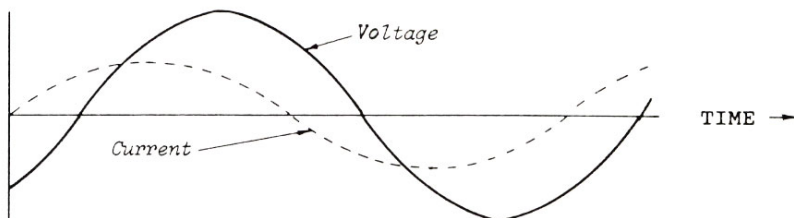

Current leads voltage.

Inductors are usually coils. The flow of electricity in an inductor produces a circular magnetic field that is proportional to the current. When the current increases, the size of the magnetic field increases and induces a voltage in the inductor. When the current decreases, the field collapses. The collapsing field reverses the polarity of the induced voltage, which opposes the decrease in current.

Because the changes of current are opposed by inductive reactance, the peak of the current wave is delayed and arrives after the peak of the voltage wave. In other words, "Current lags behind voltage".

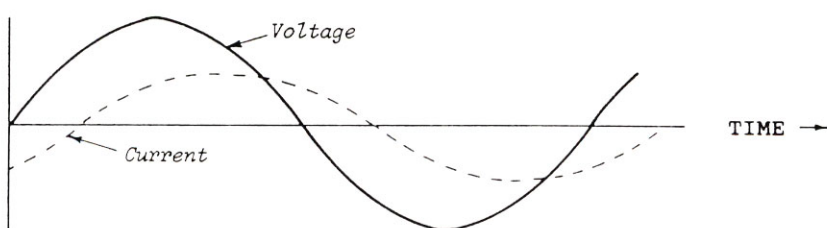

Current lags behind voltage.



## Power Factor

The power factor (PF) is the ratio of the “true” power to the “apparent” power:

$$\text{PF} = \frac{\text{true power (watts)}}{\text{apparent power (I x E) VA}}$$

When a circuit is in phase, the true power equals the apparent power, which means that the power measured by a wattmeter would be the same as the power calculated with the formula  $P = I \times E$ . In this case, the circuit is said to have a “unity” power factor or a power factor equal to 1 or 100%. If the circuit is out of phase, the power measured by the wattmeter will be less than the apparent or calculated power, and the power factor will be less than unity.

**PROBLEM:** An AC circuit draws 20 amps from a 240-volt source. The wattmeter measures 3,360 watts. What is the power factor?

- SOLUTION:**
- (1) Apparent power =  $I \times E$
  - (2) 20 amps x 240 volts = 4,800 watts
  - (3) True power = 3,360 watts
  - (4)  $\text{PF} = \text{true} / \text{apparent} = 3,360 \div 4,800 = 0.7 = 70\%$

## Power Formulas for AC Circuits

The Watt’s Law formulas for DC circuits also apply to single-phase (1 $\phi$ ) and three-phase (3 $\phi$ ) AC circuits containing only resistance.

If inductance or capacitive reactance puts the circuit out of phase, the power factor must be added to the basic power formula:

$$P = I \times E \times \text{PF}$$

**PROBLEM:** A single-phase AC circuit draws 8 amps from a 120-volt source. If the power factor is 60%, what is the power rating in watts?

- SOLUTION:**
- (1)  $P = I \times E \times \text{PF}$
  - (2)  $P = 8 \text{ amps} \times 120 \text{ volts} \times 0.6 = 576 \text{ watts}$

The formula for a three-phase (3 $\phi$ ) system includes another term called the “three-phase factor”, which is a constant equal to the square root of 3, or 1.73.

$$P_{3\phi} = I \times E \times \text{PF} \times 1.73$$

**PROBLEM:** What is the power rating in watts of a 3 $\phi$  circuit that draws 15 amps from a 120-volt source if the power factor is 70%?

- SOLUTION:**
- (1)  $P_{3\phi} = I \times E \times \text{PF} \times 1.73$
  - (2)  $P_{3\phi} = 15 \text{ amps} \times 120 \text{ volts} \times 0.7 \times 1.73 = 2,179.8 \text{ watts}$

## Transformers

Transformers consist of primary and secondary windings (coils) that are not connected to one another. The primary winding receives power from a primary source (i.e. a generator) and transfers (induces) it to the secondary winding, which is connected to a load.

A transformer can be either a step-up transformer that receives power at a low voltage and delivers it at a higher voltage, or a step-down transformer that receives power at a high voltage and delivers it at a lower voltage.

The voltage of the primary winding will be the same as the source voltage. The voltage of the secondary ( $E_s$ ) is equal to the primary voltage ( $E_p$ ) times the ratio of the number of turns ( $N_s$ ) in the secondary to the number of turns ( $N_p$ ) in the primary.

**PROBLEM:** The primary and secondary windings of a step-up transformer are shown below. If a voltage of 120 volts ( $E_p$ ) is applied across the primary, how many volts ( $E_s$ ) will be induced across the secondary?

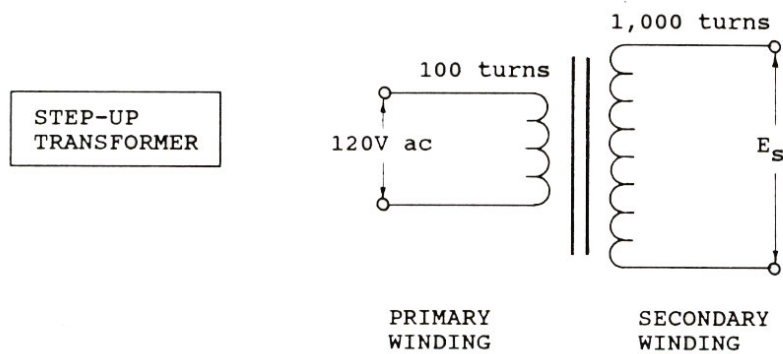

SOLUTION: (1)  $E_s = E_p \times N_s / N_p$

(2)  $E_s = 120 \text{ volts} \times 1,000 / 100 = 1,200 \text{ volts}$

**PROBLEM:** The primary and secondary windings of a step-down transformer are shown below. If a voltage of 120 volts ( $E_p$ ) is applied across the primary, how many volts ( $E_s$ ) will be induced across the secondary?

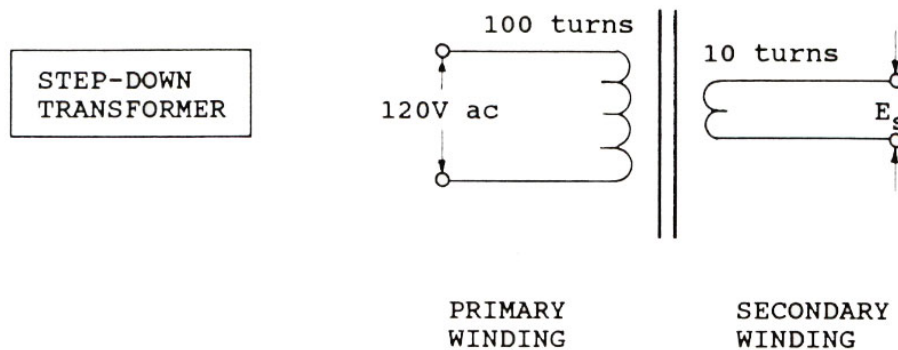

SOLUTION: (1)  $E_s = E_p \times N_s / N_p$

(2)  $E_s = 120 \text{ volts} \times 10 / 100 = 12 \text{ volts}$

The power of the primary winding equals the power of the secondary winding. Voltage and current calculations are based on this principle.

PROBLEM: The primary of a step-down transformer has a voltage ( $E_p$ ) of 2,400 volts and a current of 20 amps. If the voltage ( $E_s$ ) across the secondary is 240 volts, what is the current ( $I_s$ )?

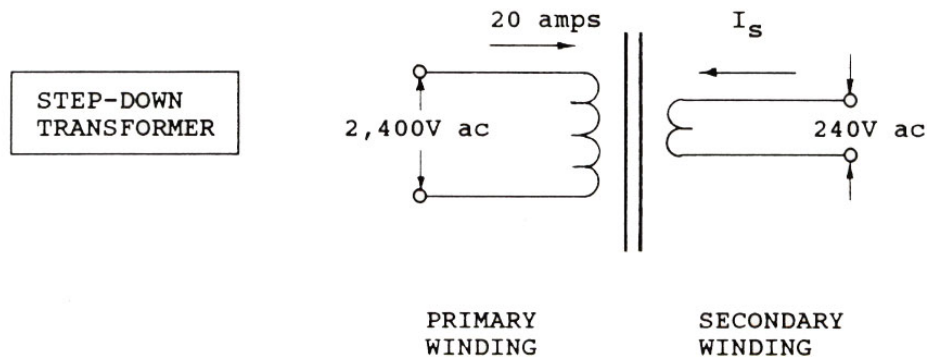

- SOLUTION: (1)  $P_p = 20 \text{ amps} \times 2,400 \text{ volts} = 48,000 \text{ watts}$
- (2) Primary power equals secondary power:  
 $P_p = P_s = 48,000 \text{ watts}$
- (3)  $I_s = P_s / E_s = 48,000 \text{ watts} \div 240 \text{ volts} = 200 \text{ amps}$



Transformers convert electricity from low to high voltage for long-distance transmission, then convert it back to low voltage for use in homes and other facilities.

## **Power Distribution**

Electrical Power Distribution will help you to understand how utility power is generated and distributed and the main system components required to distribute power throughout a building.

Power distribution and connecting the building to its permanent power source are critical items that must be considered early in the project design phase. HVAC equipment, elevators, motors, lighting, fire protection, and numerous other systems cannot be tested and inspected until permanent power has been connected. Working successfully with the electrical and mechanical superintendents requires that you have a thorough understanding of the scope of work that must be accomplished and that you are able to communicate with them efficiently.

When electrical power is distributed to its point of utilization, it is either in the form of single-phase or three-phase AC voltage. Single-phase AC voltage is distributed into residences and other small commercial buildings. Normally, three-phase AC voltage is distributed to larger commercial buildings and industrial sites.

## **Energy, Work, and Power**

An understanding of the terms energy, work, and power is necessary in the study of electrical power systems.

*Energy* means the capacity to do work. For example, the capacity to light a light bulb, to heat a home, or to move something requires energy. Energy exists in many forms, such as electrical, mechanical, chemical, and heat. Energy of an object in motion is called kinetic energy. Energy due to the position of an object that is not yet moving is called potential energy.

*Work* is the transferring or transforming of energy. Work is done when a force is exerted to move something over a distance against opposition, such as moving a desk from one side of a room to the other. An electric motor used to drive an elevator cab performs work. Work is performed when motion is accomplished against the action of a force that tends to oppose the motion. Work is also done each time energy changes from one form into another.

*Power* is the rate at which work is done. It considers not only the work that is performed but the amount of time in which the work is done. For instance, electrical power is the rate at which work is done as electrical current flows through a wire. Mechanical power is the rate at which work is done as an object is moved against opposition over a certain distance. Power is either the rate of production or the rate of use of energy. The watt is the unit of measurement of electrical power.



## Generation and Distribution of Electrical Power

Power is produced at a generating plant (source). Distribution occurs between the power generating plant and the consumer by transmission lines and substations. Transformers are used to control the voltage and current levels. Conversion of electrical power to another form (light, heat, mechanical) occurs at the customer end.

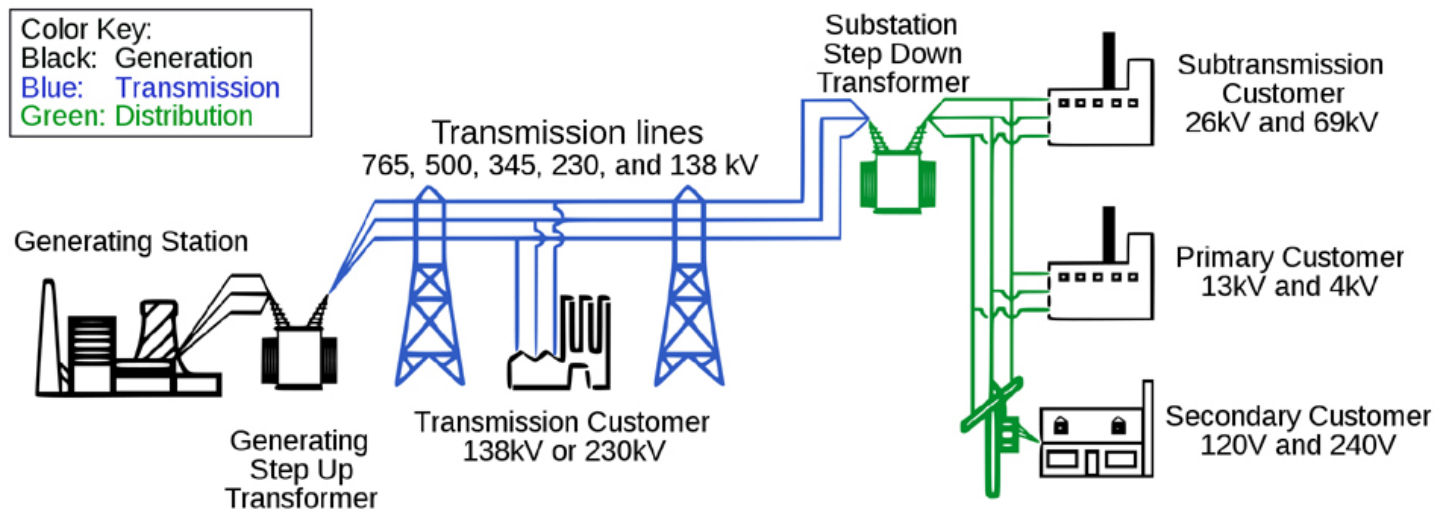

## Electrical Service Types and Voltages

Electrical service (service entrance) is the point of receiving power from the serving utility company.

## Classification of Electrical Services

Alternating current (AC) electric power distribution systems can be classified by the following properties:

- Frequency: 50 Hz or 60 Hz
- Number of phases: single or three phase
- Number of wires: 2, 3, or 4 (not counting the safety ground)
- Neutral present:
  - Wye connected systems have a neutral
  - Delta connected systems typically do not have a neutral
- Voltage levels:
  - Low Voltage: 600 volts or less
  - Medium Voltage: 601 volts to about 34,500 volts
  - High Voltage: 46,000 volts and up

Power provided from the U.S. electrical grid (the grid) is based on a frequency of 60 Hz.

## U.S. Electric Power Grid

The U.S. electric power system is the centerpiece of the Nation's economy. Virtually every aspect of American commerce and industry depends on the continuous availability of affordable electric power. This incredible feat is achieved through an extensive infrastructure of more than 19,000 generators, 55,000 transmission substations, 642,000 miles of high-voltage lines, and 6.3 million miles of distribution lines that serves more than 145 million customers.

Learn more about the "Grid" at the [Department of Energy](#) Web site.



# Common Electrical Distribution Systems

## 120/240 Volt Single Phase Three Wire System

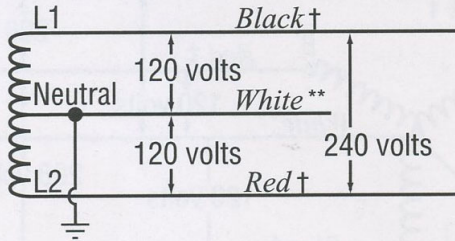

## 277/480 Volt Three Phase Four Wire System (WYE Connected)

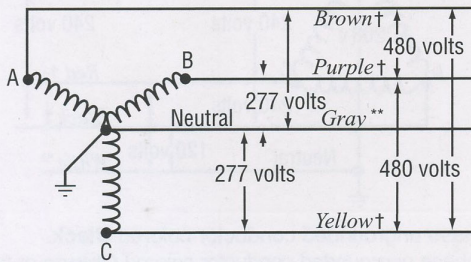

## 120/208 Volt Three Phase Four Wire System (WYE Connected)

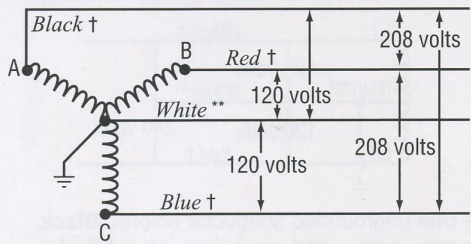

## 120/240 Volt Three Phase Four Wire System (Delta High Leg)

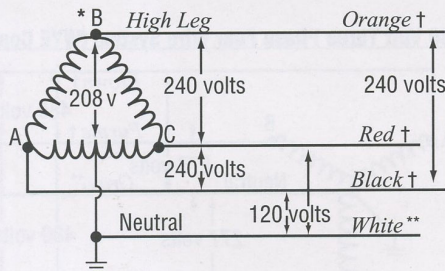

120/240-Volt, Single-Phase, Three-Wire system is the most common distribution method for residences. Most appliances and home equipment use 120 V power supplied to power receptacles. Dryers, ovens, hot water heaters, hot tubs, and other higher current requiring equipment may use the 240 V power.

Most commercial and industrial buildings use three phase power. The most commonly used incoming service voltage system is the 277/480 V Three Phase Four Wire (WYE Connected). A step-down transformer is needed to reduce the voltage to 120/208 for receptacles and other lower voltage equipment.

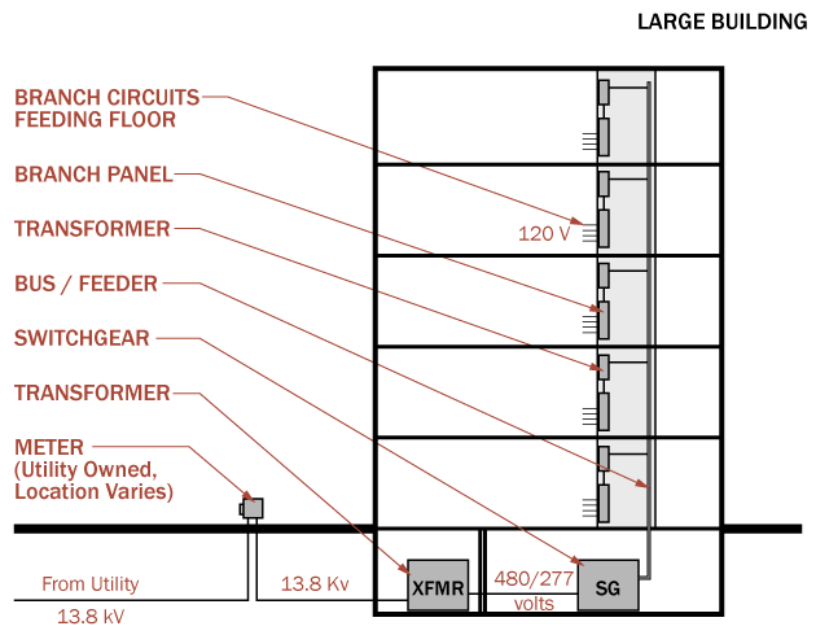

# Household distribution transformer

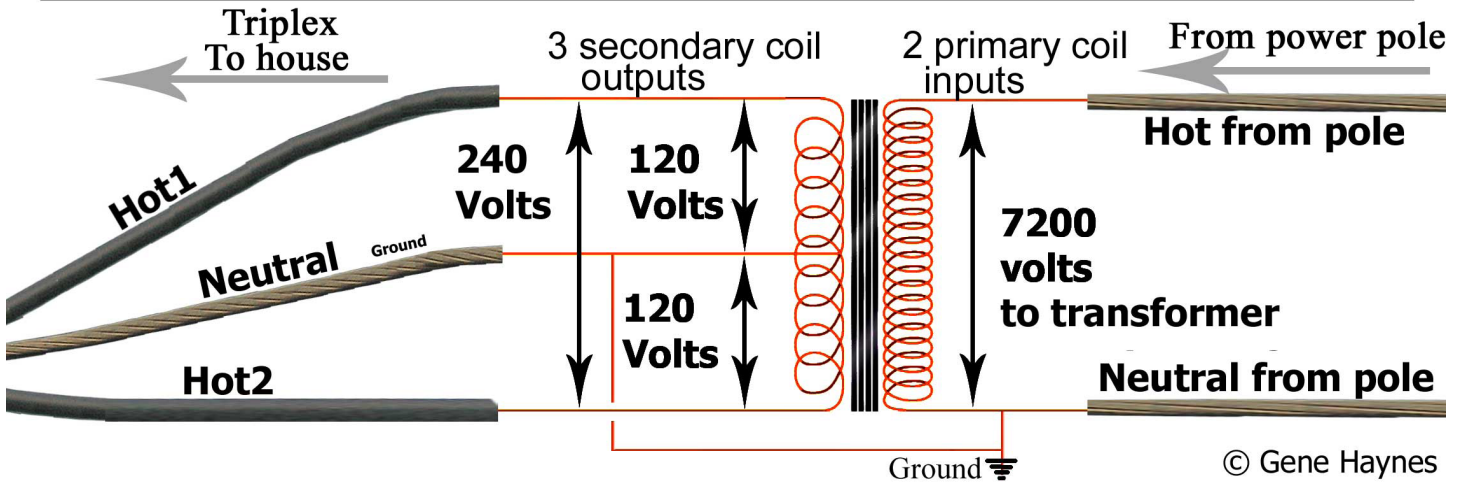

© Gene Haynes

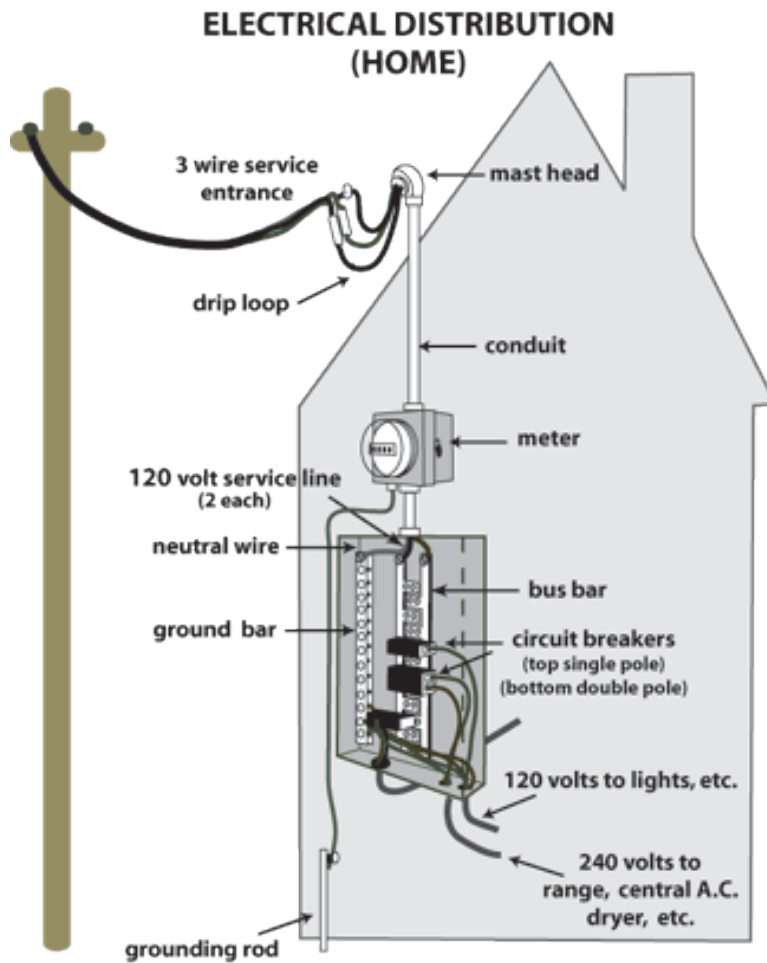

## Power Distribution System Equipment

Power distribution systems are used in every residential, commercial, and industrial building to safely control the distribution of electrical power throughout the facility.

### Residential Power Distribution

Power, purchased from a utility company, enters the house through a metering device and is applied to a load center. This is the service entrance. Residential service can come from an overhead utility transformer or from a lateral service run underground.

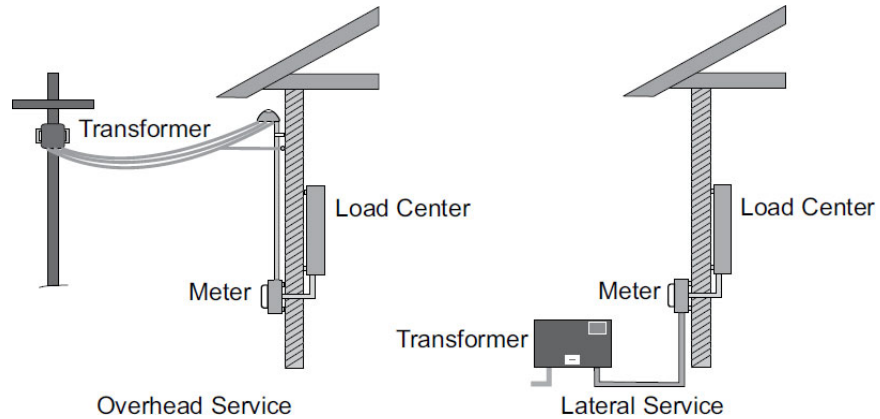

The power is then distributed by a load center to various branch circuits for lighting, appliances, and electrical outlets.

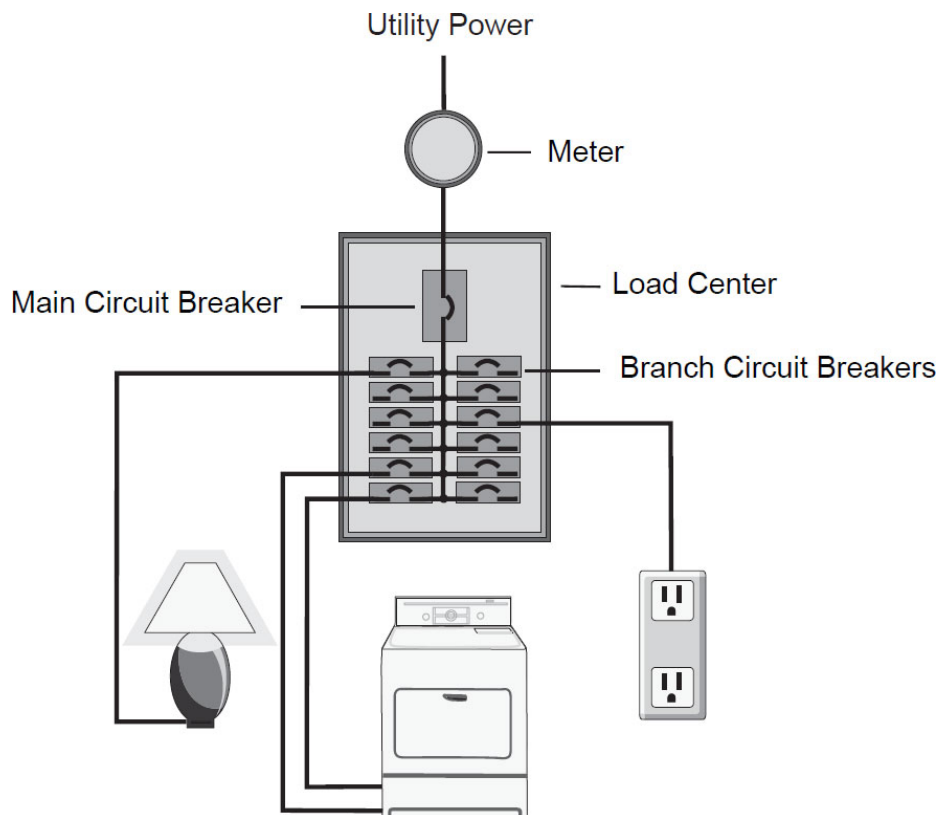

## Commercial and Industrial Power Distribution

Power distribution systems used in commercial and industrial facilities are more complex than those used in single-family homes and must be capable of handling higher levels of current and voltage. Although some small facilities usually do not require switchboards, medium and large facilities commonly use switchboards to safely distribute power to transformers, panelboards, control equipment, and, ultimately, to system loads.

### *Switchgear*

A coordinated design consisting of switching and interrupting devices and associated equipment such as control and protective devices and metering.

### *Switchboard*

A large panel or assembly of panels containing switches, overcurrent protective devices, buses, and associated instruments. Unlike panelboards, switchboards sometimes must be mounted away from a wall to allow access to rear-mounted equipment.

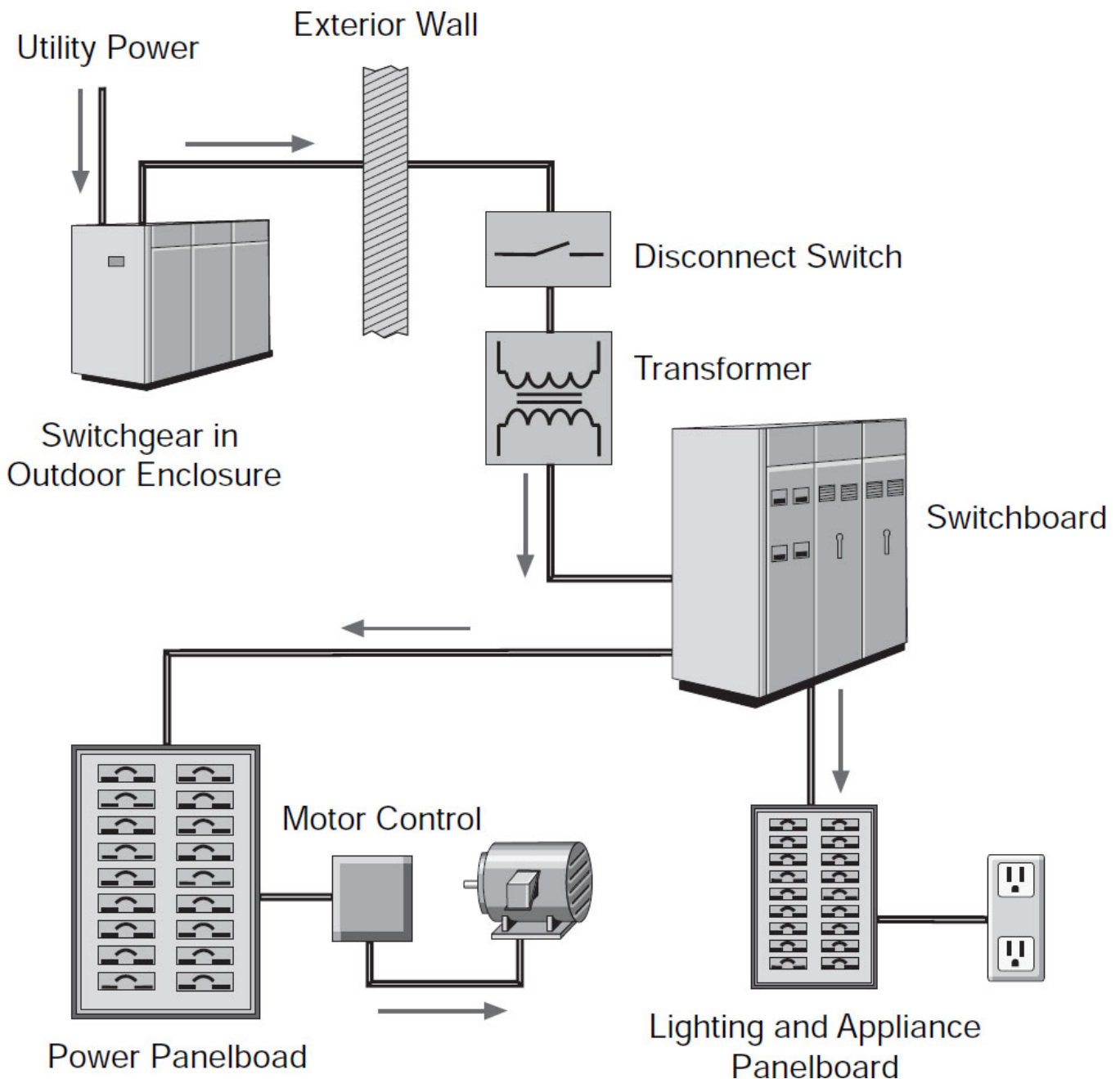



## Panelboard

A panelboard is a type of enclosure for overcurrent protection devices and the busses and connections that provide power to these devices and their associated circuits. According to the National Electrical Code® (NEC®), a panelboard is:

- Used to control light, heat, or power circuits
- Placed in a cabinet or cutout box
- Mounted in or against a wall
- Accessible only from the front

For additional information, refer to National Electrical Code® Article 408, Switchboards and Panelboards.

Panelboards are frequently divided into two categories:

- Lighting and appliance branch-circuit panelboards
- Power panelboards (also called distribution panelboards)

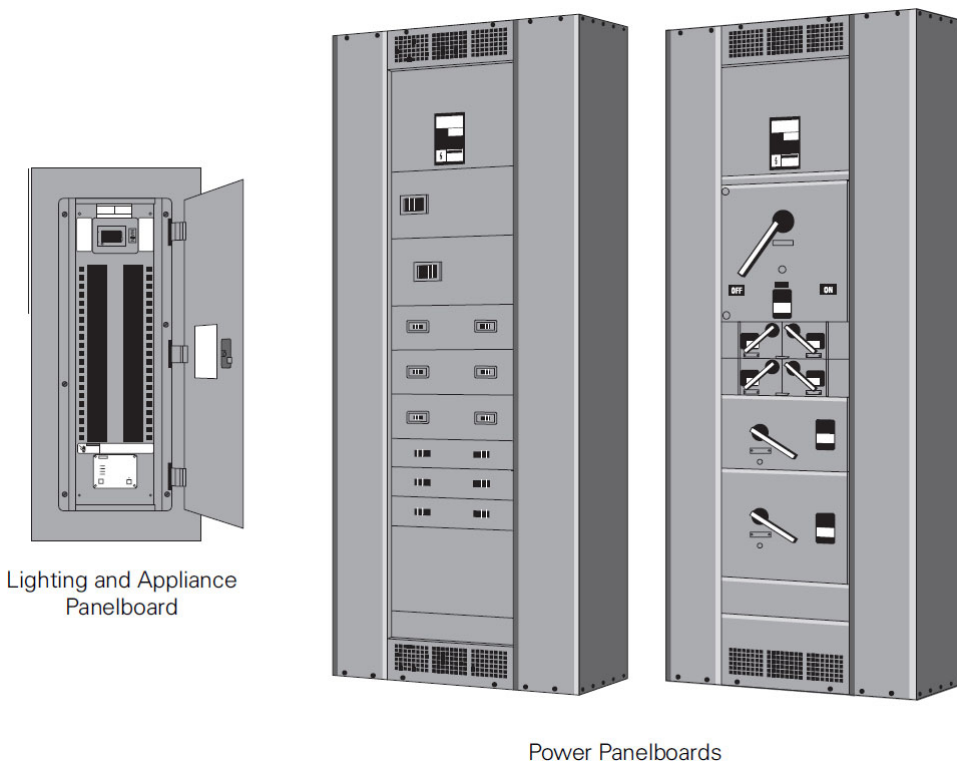

Lighting and Appliance  
Panelboard

Power Panelboards

There are three types of panelboard main configurations: main lug only, main breaker, and main switch

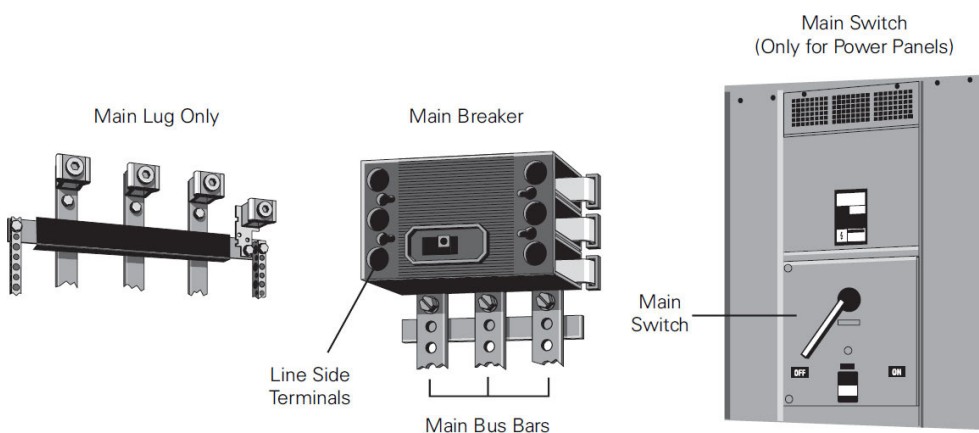

Main Lug Only

Main Breaker

Main Switch  
(Only for Power Panels)

Line Side  
Terminals

Main Bus Bars

Main  
Switch



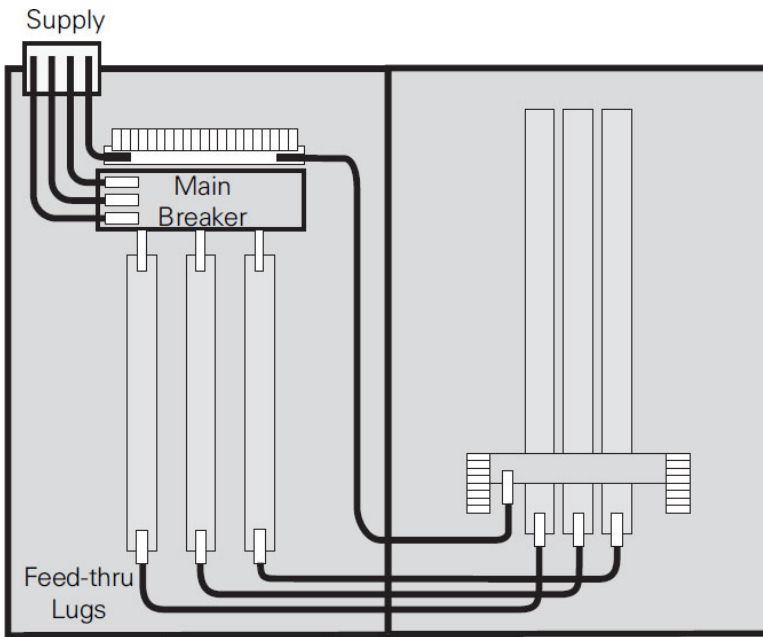

Main Breaker Panelboard

Main Lug Only Panelboard

In a Main Circuit Breaker (MCB) panelboard the entire panel can be de-energized by switching the main breaker off.

In a Main Lug Only (MLO) panelboard there is no main breaker and each individual circuit breaker must be switched off to turn off the power feeding each branch circuit.

**Overcurrent Protection Devices**

Excess heat is damaging to electrical conductors. For that reason, conductors have a rated continuous current carrying capacity or ampacity. Current beyond the rated capability of a conductor is referred to as overcurrent. Overcurrent can result from a short circuit, an overload, or a ground fault.

Fuse - A device designed to open a circuit when its rated current is exceeded. This is usually accomplished when a metal link in the fuse melts. Renewable fuses allow the user to replace the link and non-renewable fuses do not. Fuses are available in various sizes and types. Some have a time delay.

Fuse Class - A letter designation given to a fuse to identify its operating and construction characteristics.

Circuit Breaker - A device that can be used to open or close a circuit manually and also opens a circuit automatically when it senses an overcurrent.

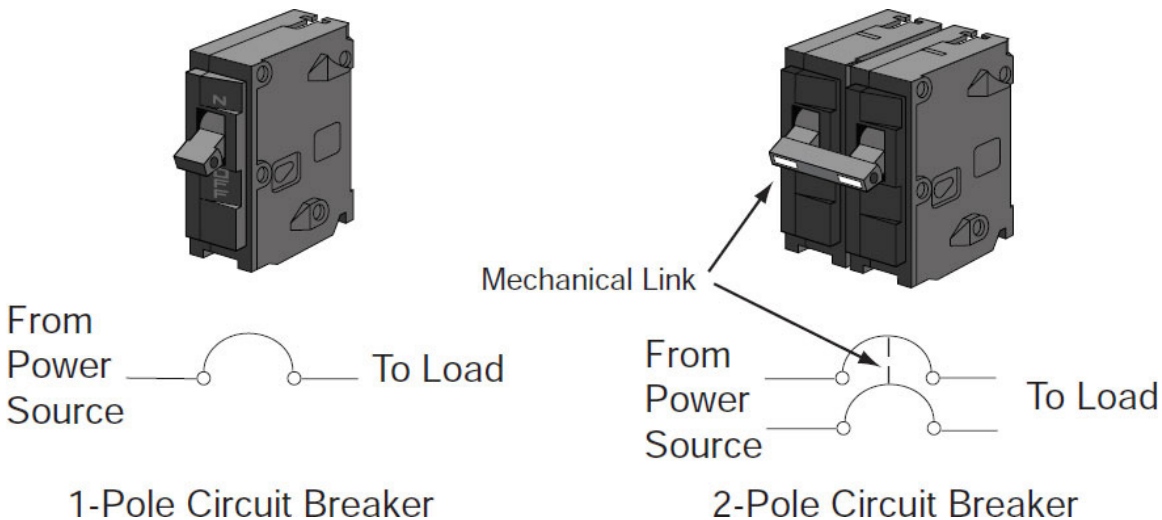

# Single-Phase Main Breaker Panelboard

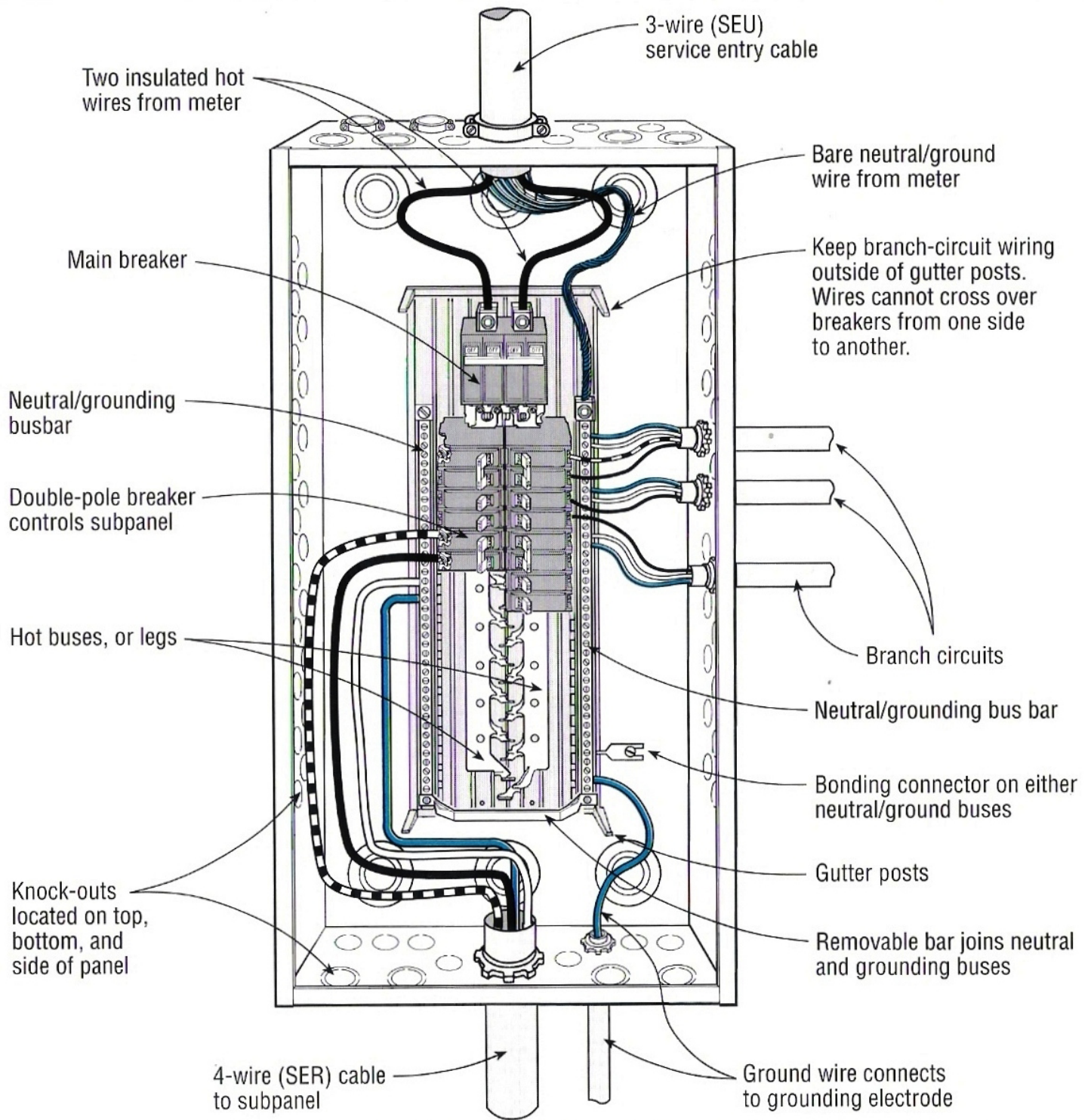

## Grounding and Bonding

Grounding is the action of electrically connecting something to a grounding electrode, which is a conductive object used to create a direct connection to ground--typically a ground rod.

A grounded conductor is a circuit conductor (wire) which is intentionally grounded.

In grounded electrical systems, like virtually all electrical systems in residential and commercial structures, the grounded conductor is the white (or gray) wire, which is commonly referred to as the "neutral" or most correctly referred to as a "grounded neutral conductor". A grounded wire is required by the National Electrical Code to be white or gray in color on the customer side of the meter.

Since the neutral is a necessary part of the electrical path for the current to return to the source, neutral conductors carry current under normal operating conditions.

A "grounding" wire on the other hand is a safety wire that has intentionally been connected to earth. The grounding wire does not carry electricity under normal circuit operations. It's purpose is to carry electrical current only under short circuit or other conditions that would be potentially dangerous.

Grounding wires serve as an alternate path for the current to flow back to the source, rather than go through anyone touching a dangerous appliance or electrical box.

Confusion arises because it is commonly referred to as a ground wire even though it is more correctly called a "grounding" wire. Some people will refer to this wire as the "case ground" since this wire is typically connected to the cases or outer parts of electrical boxes and appliances and tools.

The grounding wire is required by the National Electrical Code to be a bare wire, or if insulated, a green or green with yellow colored insulation.

Grounding also serves another purpose which is not really related to safety: It provides a common reference point for voltage. If an electrical device's only connections are to the two ends of its power source, it is electrically unstable and the voltage levels may vary. Neither one would be at zero volts. Because planet Earth stays at a common voltage, it provides a universal voltage reference point. (The planet is usually considered to be at zero volts, even though this is not perfectly true, as Earth itself is something of a conductor.)

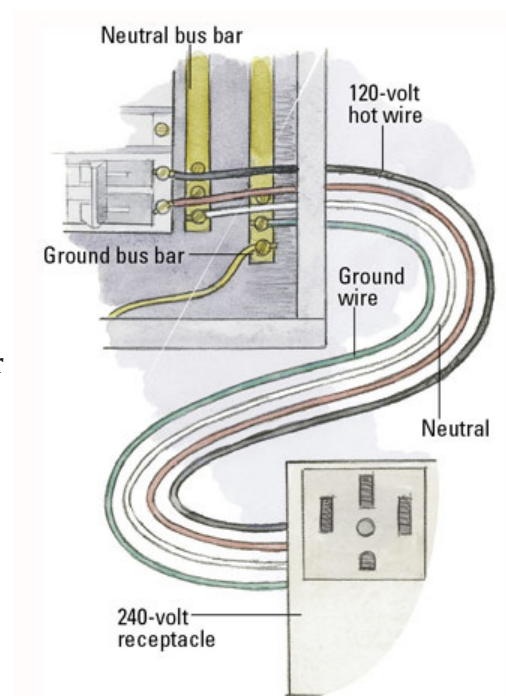



Bonding, or equipotential bonding, is essentially an electrical connection maintaining various exposed conductive parts and extraneous conductive parts at substantially the same potential. An earthed equipotential zone is one within which exposed conductive parts and extraneous conductive parts are maintained at substantially the same potential by bonding, such as that, under fault conditions, the difference in potential between simultaneously accessible exposed and extraneous conductive parts will not cause electric shock. Bonding is the practice of connecting all accessible metalwork – whether associated with the electrical installation (known as exposed metalwork) or not (extraneous metalwork) – to the system earth.

In a building, there are typically a number of services other than electrical supply that employ metallic connections in their design. These include water piping, gas piping, HVAC ducting, and so on. A building may also contain steel structures in its construction. There is thus a possibility that a dangerous potential may develop between the conducting parts of non-electrical systems including building structures and the external conducting parts of electrical installations as well as the surrounding earth. This may give rise to undesirable current flow through paths that are not normally designed to carry current (such as joints in building structures) and also cause hazardous situations of indirect shock.

It is therefore necessary that all such parts are bonded to the electrical service earth point of the building to ensure safety of occupants. This is called equipotential bonding. There are two aspects to equipotential bonding: the main bonding where services enter the building and supplementary bonding within rooms, particularly kitchens and bathrooms.

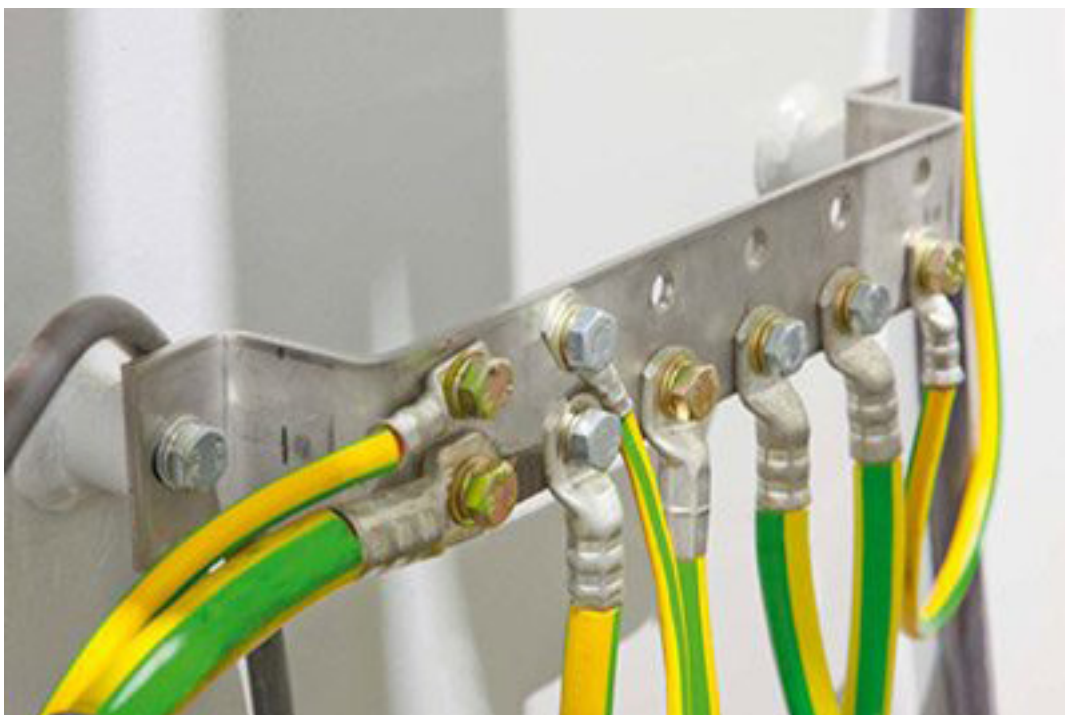

## Components of an Effective Grounding System

An effective grounding system is one of the most important aspects of ensuring lightning protection. The purpose of this system is to provide a pathway for the lightning energy to safely flow to earth, as if this is not effective the extreme current -given the conditions- can find alternate pathways. If the current does deviate, the damage can range from electromagnetic interference on sensitive equipment and overloading circuits to electrical fires, arc flash and electrocution. For this reason, it is crucial to consult professionals when implementing one of these systems.

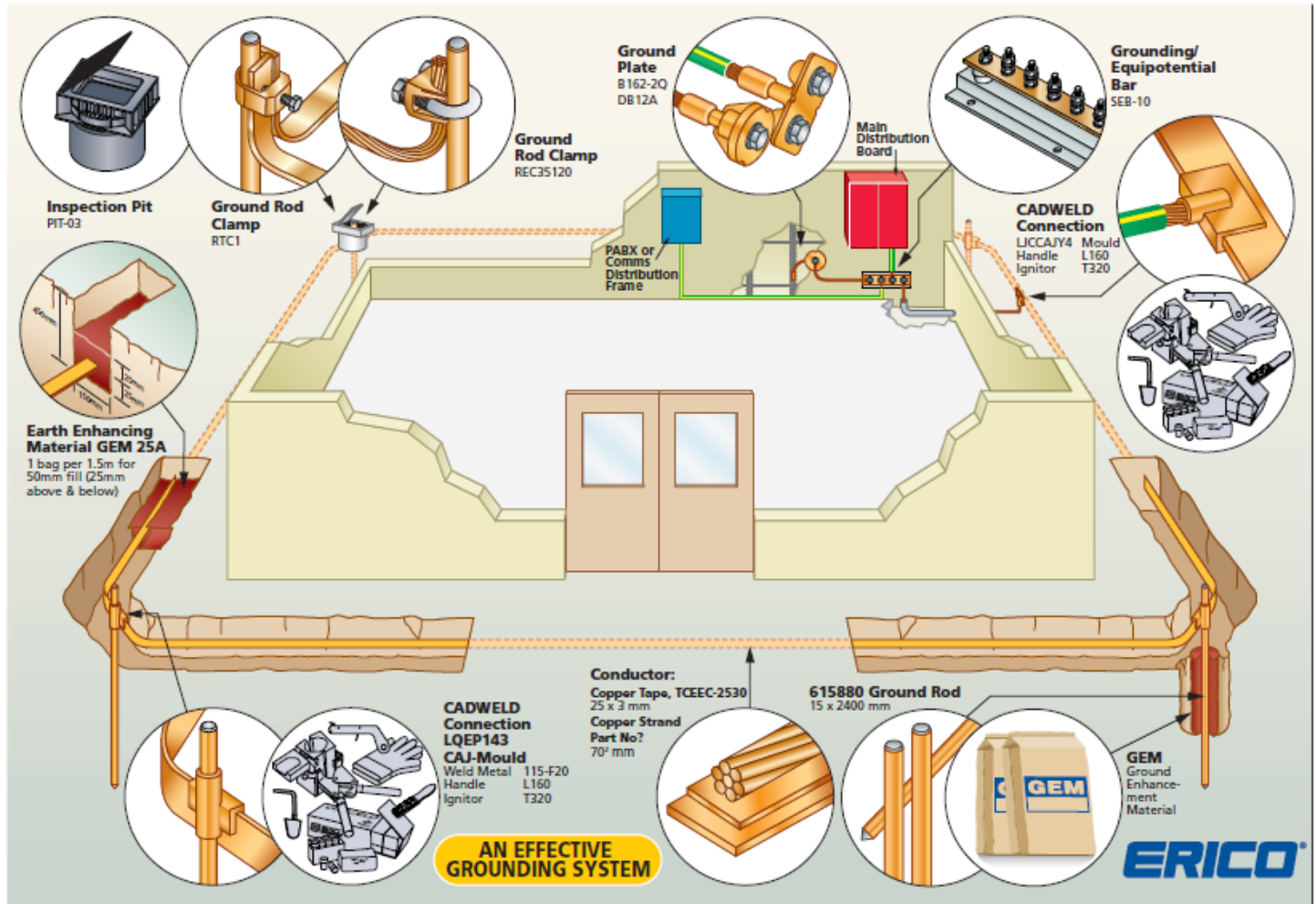

- 1. Earthing network conductor.** Conductor must have the current carrying capacity for the maximum fault current for the total clearing time of the fault. Copper or copper-bonded steel conductors are characteristically used for this purpose. WAPP offers various types of conductors for earth grids and bonding ranging from flat copper tape, various copper earth cables to proprietary ERICO Smoothweave cables.
- 2. Interconnecting Joints.** Connections between grounding conductors are essential to the functionality and reliability of the system, this is how the elements of the grounding system tie together. Exothermically welding the connections, by use of CADWELD provides a superior bond on a molecular level ensuring that it will never corrode or loosen which would otherwise damage the integrity of the electrical continuity. A more economical and procedurally simple alternative are mechanical connectors, these are of bolted, wedge and crimp type which, rely on the physical surface contact to maintain electrical connection. For above ground connections (e.g. fence clamps), this is an acceptable way of bonding.



3. **Grounding Electrode.** The grounding electrode (or sometimes referred to as rod/stake provides electrical connection to the ground and acts to dissipate current to it. Electrodes can be categorised as either “natural” or “made”. A natural electrode is intrinsic to the structure this could be metal underground water piping, effectively grounded metal framework of the facility, and/or the steel in reinforced concrete foundations. An electrode is considered made when it is implemented for the express function of improving the performance a grounding system this includes buried metal plates, buried mesh conductor and rods or pipes driven into the ground.



The ground rod is the single most used, efficient and effective grounding device in the practice today. ERICO has developed bonded ground rods impervious to many issues common in cheaper ground rods, further information see copper ground rods.

4. **Soil Composition.** The soil resistivity rating, a measure of ohm-meters, has a large impact on the performance of a grounding system and is to be known prior to engineering a proper grounding system. Based off the soil resistivity the design engineer will locate the area of the most conductive soil and from this, determine the depth the electrodes required to be placed accordingly.

The best solution to improving earth composition can be altered to decrease its resistivity through the use of the cost effective Ground Enhancing Material (GEM). The optimal solution is the effective implementation of GEM to reach the desired resistance. There are other solutions such as bentonite which perform the same task however, are deemed inferior, for more information on this see GEM vs Bentonite.



5. **Electrode to Earth Resistivity.** Rod surface area and earth composition are the main contributing factors. Doubling radius of the driven rod will reduce resistance by merely 10% and is not a cost-effective option. Doubling the rod length however, will theoretically reduce resistance by 40%. Placement of numerous rods that are driven to a predetermined depth in low resistivity soil.

More information can be found at: <https://www.erico.com/>

## **Electrical Material**

An electrical contractor is a business person or firm that performs specialized construction work related to the design, installation, and maintenance of electrical and communication systems.

An electrician is someone trained (and usually licensed) to perform electrical work. Electrical work is a highly technical profession that requires a thorough understanding of how electricity works and the materials and components used to deliver power, as well as electrical safety and standards.

An electrician can be employed by an electrical contracting firm or self-employed as an individual electrical contractor.

To organize an electrical estimate and efficiently order and supply the correct material needed for a job, electrical material is typically categorized.

## **National Electrical Contractors Association (NECA)**

The National Electrical Contractors Association (NECA) is the voice of the \$171 billion industry responsible for bringing electrical power, lighting and communications to buildings and communities across the United States.

NECA members are electrical contractors who work in all aspects of electrical construction. While most qualify as small businesses, large, multi-area electrical contracting firms are also members of the association.

NECA contractors are the technical professionals responsible for the most innovative and safest electrical construction in the U.S. They hold a high standard for superior performance and are committed to delivering quality results.

## **NECA Manual of Labor Units**

The NECA Manual of Labor Units (MLU) has been developed, published and utilized by electrical contractors since 1923. The MLU provides an experience-based reference for estimating the electrical construction labor required to install typical electrical and communications systems. The data is intended to serve as a general guide to the labor necessary for the installation of specified items under the project conditions defined in the manual. The extent of the applicability of the data to any particular project situation is entirely at the discretion of each user.

Selected areas within the manual are reviewed and updated bi-annually by estimating experts from among the NECA electrical contractors located across the country. These individuals represent many years of experience in estimating, tracking the applications of labor units to construction projects and the installation of materials for a broad range of conditions and locations. The resulting labor unit determinations represent a national consensus baseline of estimated labor requirements for each item under the conditions stated.

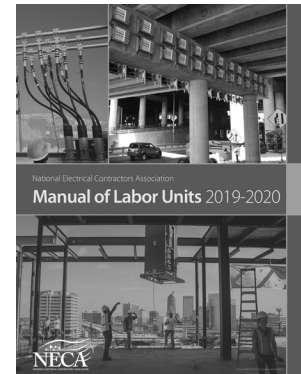

## **Labor Units Defined**

All labor data in this manual are in units of man-hours. Each table of labor units indicates whether the labor units are for the installation of:

E	=	One, or per each item
C	=	Per hundred items or per hundred linear feet of the item
M	=	Per thousand items or per thousand linear feet of the item
LF	=	Linear Foot
CY	=	Cubic Yard

## **Arrangement of the Labor Unit Tables**

All labor units within the manual have been organized to correspond with the Construction Specification Institute's MasterFormat, 2018 Edition, and the manual has been laid out accordingly.

### **Labor Unit Data**

Section 1: Division 01—General Requirements

01 51 00: Temporary Utilities

Section 2: Division 03—Concrete

03 21 00: Reinforcement Bars

03 22 00: Fabric and Grid Reinforcing

Section 3: Division 11—Equipment

11 11 00: Vehicle Service Equipment

Section 4: Division 13—Special Construction

13 47 00: Facility Protection

Section 5: Division 21—Fire Suppression

21 05 00: Common Work Results for Fire Suppression

Section 6: Division 22—Plumbing

22 05 00: Common Work Results for Plumbing

Section 7: Division 23—Heating, Ventilating and Air Conditioning (HVAC)

23 05 00: Common Work Results for HVAC

23 09 00: Instrumentation and Control for HVAC

23 34 00: HVAC Fans

23 82 00: Convection Heating and Cooling Units

23 83 00: Radiant Heating and Cooling Units

Section 8: Division 26—Electrical

26 05 00: Common Work Results for Electrical

26 05 05: Selective Demolition for Electrical

26 05 13: Medium-Voltage Cables

26 05 19: Low-Voltage Electrical Power Conductors and Cables

26 05 23: Control-Voltage Electrical Power Cables

26 05 26: Grounding and Bonding for Electrical Systems

26 05 29: Hangers and Supports for Electrical Systems

26 05 33: Raceway and Boxes for Electrical Systems

26 05 36: Cable Trays for Electrical Systems

- 26 05 39: Underfloor Raceways for Electrical Systems
- 26 05 43: Underground Ducts and Raceways for Electrical Systems
- 26 05 44: Sleeves and Sleeve Seals for Electrical Raceways and Cabling
- 26 05 83: Wiring Connections
- 26 06 00: Schedules for Electrical
- 26 09 00: Instrumentation and Control for Electrical Systems
- 26 12 00: Medium-Voltage Transformers
- 26 13 00: Medium-Voltage Switchgear
- 26 21 00: Low-Voltage Electrical Service Entrance
- 26 22 00: Low-Voltage Transformers
- 26 24 00: Switchboards and Panelboards
- 26 25 00: Low-Voltage Enclosed Bus Assemblies
- 26 27 00: Low-Voltage Distribution Equipment
- 26 28 00: Low-Voltage Circuit Protective Devices
- 26 29 00: Low-Voltage Controllers
- 26 31 00: Photovoltaic Collectors
- 26 32 00: Packaged Generator Assemblies
- 26 33 00: Battery Equipment
- 26 35 00: Power Filters and Conditioners
- 26 36 00: Transfer Switches
- 26 41 00: Facility Lightning Protection
- 26 43 00: Surge Protective Devices
- 26 51 00: Interior Lighting
- 26 52 00: Safety Lighting
- 26 54 00: Classified Location Lighting
- 26 55 00: Special Purpose Lighting
- 26 56 00: Exterior Lighting

Section 9: Division 27—Communications

- 27 05 00: Common Work Results for Communications
- 27 11 00: Communications Equipment Room Fittings
- 27 13 00: Communications Backbone Cabling
- 27 15 00: Communications Horizontal Cabling
- 27 16 00: Communications Connecting Cords, Devices and Adapters
- 27 21 00: Data Communications Network Equipment
- 27 22 00: Data Communications Hardware
- 27 24 00: Data Communications Peripheral Data Equipment
- 27 31 00: Voice Communications Switching and Routing Equipment
- 27 33 00: Voice Communications Messaging
- 27 41 00: Audio-Video Systems
- 27 51 00: Distributed Audio-Video Communications Systems
- 27 52 00: Healthcare Communications and Monitoring Systems
- 27 53 00: Distributed Systems

Section 10: Division 28: Electronic Safety and Security

- 28 05 00: Common Work Results for Electronic Safety and Security
- 28 14 00: Access Control System Hardware
- 28 15 00: Integrated Access Control Hardware Devices
- 28 16 00: Access Control Interfaces
- 28 20 00: Video Surveillance

28 21 00: Surveillance Cameras  
28 25 00: Video Surveillance Positioning Equipment  
28 31 00: Intrusion Detection  
28 46 00: Fire Detection and Alarm

Section 11: Division 31 — Earthwork

31 05 00: Common Work Results for Earthwork  
31 23 00: Excavation and Fill  
31 25 00: Erosion and Sedimentation Controls  
3 1 41 00: Shoring

Section 12: Division 32 — Exterior Improvements

32 17 00: Paving Specialties

Section 13: Division 33 — Utilities

33 05 00: Common Work Results for Utilities  
33 71 00: Electrical Utility Transmission and Distribution  
33 73 00: Utility Transformers  
33 77 00: Medium-Voltage Utility Switchgear and Protection Devices  
33 79 00: Site Grounding

Section 14: Division 34 — Transportation

34 41 00: Roadway Signaling and Control Equipment  
34 43 00: Airfield Signaling and Control Equipment  
34 71 00: Roadway Construction

Section 15: Division 48 — Electrical Power Generation

48 14 00: Solar Energy Electrical Power Generation Equipment  
48 15 00: Wind Energy Electrical Power Generation Equipment  
48 18 00: Fuel Cell Electrical Power Generation Equipment  
48 30 00: Combined Heat and Power Generation



**The NECA labor unit tables include three different labor units for each item:**

NECA 1	Normal N
NECA 2	Difficult D
NECA 3	Very Difficult VD

**Normal Installation Conditions** – When all of the conditions associated with the installation of an item will permit the maximum productivity of the electricians on a project, these “normal” column labor units are applicable.

Examples of these normal conditions might include the installation of surface mounted items up to a height of ten feet above the floor, the use of a rolling scaffold or six-foot ladders, a repetitive layout, a minimum of required measurements, a minimum of interference by structural or mechanical obstacles, etc.

Occasionally there are unusual installation conditions when a labor unit that is less than the “normal” column labor unit is justified. For example, when an abnormally large quantity of parallel conduits, without bends or offsets, are to be installed on trapeze hangers, labor units slightly smaller than the “normal” column labor units might be appropriate.

**Difficult Installation Conditions** – When one or more of the conditions associated with the installation of an item will permit less than maximum productivity of the electricians on a typical project, these “difficult” column labor units are applicable.

Examples of the difficult conditions might include the installation of surface mounted items up to a height of twenty feet from the floor, the use of fixed scaffolding installed by others, the use of ten-foot ladders, a non-repetitive layout, a moderate amount of interference by structural or mechanical obstacles, etc.

Users of this manual are also encouraged to consider using labor units whose magnitude are somewhere between the normal column labor units and the difficult column labor units when conditions justify this consideration.

**Very Difficult Installation Conditions** – When one or more of the conditions associated with the installation of an item will permit substantially less than maximum productivity of the electricians on a typical project, these “very difficult” column labor units are applicable.

Examples of the very difficult conditions might include the installation of surface mounted items greater than the height of twenty feet above the floor, the use of fixed scaffolding installed by others, the use of man-lifts, an individual location of each item, a substantial amount of interference by structural or mechanical items, a difficult fastening method, etc.

Users of this manual are also encouraged to consider using labor units whose magnitude are somewhere between the difficult column labor units and the very difficult column labor units when the conditions justify this consideration. It is also essential that users of this manual select labor units that are greater than the very difficult column labor unit when conditions justify the need.

For more information on adjusting labor units and how to use the guide see: Introduction to the NECA Manual of Labor Units, in the NECA 2019-2020 MLU.

## NECA Categories of Work

Prior to 2018 the NECA Manual of Labor Units was organized into 14 categories of electrical material.





SECTION	TITLE
01	Integrated Building Systems
02	Conduit, Raceways, Fittings, & Related Items
03	Wire, Cable, Lugs, Terminations, Busway & Bus Duct
04	Switchboards, MCC's, Panelboards, & Power Equipment
05	Lighting Fixtures, Poles, Parking Lot Lighting
06	Wiring Devices
07	Hazardous Systems
08	Grounding & Lighting Protection Systems
09	Heating Equipment Connections
10	Temporary Power & Lighting
11	Outdoor Overhead and Underground Systems
12	Equipment Installation and Connections
13	Industrial Control and Instrumentation
14	Alternative Energy Systems

Many electrical contractors use a different breakdown of electrical material for estimating purposes. The beginning estimator should consult with the chief estimator and follow the system established by their company for preparing their estimates.

The same information can be found in the newer version (NECA Manual of Labor Units 2019-2020 Edition) under the Construction Specification Institute's MasterFormat, 2018 Edition. For example, Section 06 Wiring Devices can now be found in Section 8: Division 26 - Electrical: 26 27 00: Low-Voltage Distribution Equipment.



Section 8: Division 26 - Electrical addresses labor units related to general electrical workings as well as more specific areas of electrical construction. Labor units in this Division were previously found in nearly all sections of the previous versions of the NECA Manual of Labor Units.

Section 6 - Wiring Devices

Description	Rev	Normal	Difficult	Very Difficult	Company Experience	Unit
<b>Single Receptacle - Straight Blade or Twist Lock</b>						
 15 Amp 3 Wire		25.00	31.25	37.50		C
 20 Amp 3 Wire		30.00	37.50	45.00		C
20 Amp 4 Wire		35.00	43.75	52.50		C
20 Amp 5 Wire		40.00	50.00	60.00		C
30 Amp 3 Wire		40.00	50.00	60.00		C
30 Amp 4 Wire		45.00	56.25	67.50		C
30 Amp 5 Wire		50.00	62.50	75.00		C
50 Amp 3 Wire		50.00	62.50	75.00		C
50 Amp 4 Wire		55.00	68.75	82.50		C
60 Amp 3 Wire		60.00	75.00	90.00		C
60 Amp 4 Wire		70.00	87.50	105.00		C
<b>Duplex Receptacle - Straight Blade</b>						
 15 Amp 3 Wire		25.00	31.25	37.50		C
15 Amp GFCI or AFCI	X	30.00	37.50	45.00		C
20 Amp 3 Wire		30.00	37.50	45.00		C
20 Amp GFCI or AFCI	X	35.00	43.75	52.50		C
15 Amp 3 Wire with USB Ports	X	25.00	31.25	37.50		C
20 Amp 3 Wire with USB Ports	X	30.00	37.50	45.00		C
GFCI - Blank Face	X	30.00	37.50	45.00		C
<b>Split Wired Receptacle - Straight Blade</b>						
 15 Amp 3 Wire		35.00	43.75	52.50		C
 20 Amp 3 Wire		40.00	50.00	60.00		C
<b>Plugtail Wired Receptacles-Straight Blade</b>						
 15 Amp 3 Wire	X	15.00	18.75	23.44		C
15 Amp GFCI	X	20.00	25.00	31.25		C
20 Amp 3 Wire	X	20.00	25.00	31.25		C
20 Amp GFCI	X	25.00	31.25	39.00		C
<b>Plugtail Wired Switches</b>						
 15 Amp 1 pole	X	10.00	12.50	15.00		C
20 Amp 1 pole	X	15.00	18.75	22.50		C
15 Amp 2 pole		20.00	25.00	30.00		C
20 Amp 2 pole		25.00	31.25	37.50		C
15 Amp 3 Way		25.00	31.25	37.50		C
20 Amp 3 Way		30.00	37.50	45.00		C
15 Amp 4 Way		30.00	37.50	45.00		C
20 Amp 4 Way		35.00	43.75	52.50		C
<b>Plugtail Connectors</b>						
 6" angle solid wire		10.00	12.50	15.00		C
6" stranded wire		10.00	12.50	15.00		C
6" angle solid wire with wago connector		10.00	12.50	15.00		C
6" angle stranded wire with wago connector		10.00	12.50	15.00		C

6

Section 8: Division 26—Electrical

	Description	Rev	Normal	Difficult	Very Difficult	Company Experience	Unit
	<b>Single Receptacle - Straight Blade or Twist Lock</b>						
	15 Amp 3 Wire		25.00	31.25	37.50		C
	20 Amp 3 Wire		30.00	37.50	45.00		C
	20 Amp 4 Wire		35.00	43.75	52.50		C
	20 Amp 5 Wire		40.00	50.00	60.00		C
	30 Amp 3 Wire		40.00	50.00	60.00		C
	30 Amp 4 Wire		45.00	56.25	67.50		C
	30 Amp 5 Wire		50.00	62.50	75.00		C
	50 Amp 3 Wire		50.00	62.50	75.00		C
	50 Amp 4 Wire		55.00	68.75	82.50		C
	60 Amp 3 Wire		60.00	75.00	90.00		C
	60 Amp 4 Wire		70.00	87.50	105.00		C
	<b>Duplex Receptacle - Straight Blade</b>						
	15 Amp 3 Wire		25.00	31.25	37.50		C
	15 Amp GFCI or AFCI		30.00	37.50	45.00		C
	20 Amp 3 Wire		30.00	37.50	45.00		C
	20 Amp GFCI or AFCI		35.00	43.75	52.50		C
	15 Amp 3 Wire with USB Ports		25.00	31.25	37.50		C
	20 Amp 3 Wire with USB Ports		30.00	37.50	45.00		C
	GFCI - Blank Face		30.00	37.50	45.00		C
	<b>Split Wired Receptacle - Straight Blade</b>						
	15 Amp 3 Wire		35.00	43.75	52.50		C
	20 Amp 3 Wire		40.00	50.00	60.00		C
	<b>Plugtail Wired Receptacles - Straight Blade</b>						
	15 Amp 3 Wire		15.00	18.75	23.44		C
	15 Amp GFCI		20.00	25.00	31.25		C
	20 Amp 3 Wire		20.00	25.00	31.25		C
20 Amp GFCI		25.00	31.25	39.00		C	
	<b>Plugtail Wired Switches</b>						
	15 Amp 1 Pole		10.00	12.50	15.00		C
	20 Amp 1 Pole		15.00	18.75	22.50		C
	15 Amp 2 Pole		20.00	25.00	30.00		C
	20 Amp 2 Pole		25.00	31.25	37.50		C
	15 Amp 3 Way		25.00	31.25	37.50		C
	20 Amp 3 Way		30.00	37.50	45.00		C
	15 Amp 4 Way		30.00	37.50	45.00		C
20 Amp 4 Way		35.00	43.75	52.50		C	
	<b>Plugtail Connectors</b>						
	6-inch Angle Solid Wire		10.00	12.50	15.00		C
	6-inch Stranded Wire		10.00	12.50	15.00		C
	6-inch Angle Solid Wire with Wago Connector		10.00	12.50	15.00		C
6-inch Angle Stranded Wire with Wago Connector		10.00	12.50	15.00		C	

## Section 8: Division 26 - Electrical

### 26 05 33: Raceway and Boxes for Electrical Systems

#### General Information

Conduit, Raceways, Fittings and Related Items

- Measuring, cutting, threading and handling conduit
- Material assembly and installation
- Conduit offset bending

Electrical conduits are used to protect and provide the route of electrical wiring. Electrical conduits (ECs) are made of metal, plastic, or fiber and can be rigid or flexible. The National Electric Code (NEC) sets standards for the installation for conduits and other raceways.

#### Common Types of Conduit

##### Steel Conduits

Steel conduit has been in use as a “raceway system” for electrical conductors since the early 1900s. The strength of steel makes galvanized steel rigid conduit, intermediate metal conduit and electrical metallic tubing the wiring methods recognized as providing superior mechanical protection to the enclosed wire conductors. Additionally, a properly installed metal raceway system is recognized by the National Electrical Code® (NEC) as an equipment grounding conductor. The basic types of steel raceways in use today are steel rigid metal conduit (RMC), intermediate metal conduit (IMC) and electrical metallic tubing (EMT).

##### *Rigid Metal Conduit (RMC)*

Steel RMC has the thickest-wall of the steel raceways. It is available with either a straight-tapped or integral coupling. Galvanized Steel RMC may have a primary coating of zinc on the exterior and interior of the conduit; a combination of zinc and nonmetallic coating are also permitted. Supplementary coatings can be applied for additional corrosion protection.



##### Electrical Code Compliance

The National Electrical Code® Article 344 covers rigid metal conduit, which includes galvanized and stainless steel, aluminum and red brass. Steel RMC is permitted in all atmospheric conditions and occupancies. The listing label for this product will be identified with one of the following: “Electrical Rigid Metal Conduit” or “ERMC-S”.

##### RMC Trade Sizes

RMC is available in trade sizes 1/2 through 6, and 10' and 20' lengths. RMC is threaded on both ends, with a coupling applied to one and a color-coded thread protector on the other. The industry-established color-coded thread protectors aid in product and trade size recognition. Thread protectors for trade sizes 1, 2, 3, 4, 5 and 6 are color coded blue; trade sizes 1/2, 1 1/2, 2 1/2 and 3 1/2 are black; and trade sizes 3/4 and 1 1/4 are red.

##### Steel RMC Corrosion Protection

A variety of coating options are available to protect galvanized steel RMC against corrosion. ERMC-S is provided with zinc, zinc-based, nonmetallic, or other alternate corrosion-resistant exterior coating and an organic or zinc interior coating.

Other Trade Names: Galvanized Rigid Conduit (GRC), Galvanized Rigid Steel (GRS)



### Intermediate Metal Conduit (IMC)

IMC was developed in the 1970s as a thin-wall alternative to rigid metal conduit (RMC) that weighs about one-third less. IMC ships with either a straight-tapped or integral coupling. It features a galvanized OD and corrosion-resistant ID coating.



#### Electrical Code Compliance

IMC is covered under Article 342 in the NEC®.

#### IMC Sizing

IMC is available in trade sizes 1/2 through 4, and 10' lengths. Threads on the uncoupled end are covered by industry color-coded thread protectors to protect the threads, keep them clean and sharp, and aid in trade size recognition. Thread protectors for trade sizes 1, 2, 3 and 4 are color-coded orange; trade sizes 1/2, 1 1/2, 2 1/2 and 3 1/2 are yellow; and trade sizes 3/4 and 1 1/4 are green.

#### Using IMC as a Substitute for RMC

IMC is interchangeable with galvanized RMC. Both have threads with a 3/4-inch-per-foot taper, use the same couplings and fittings, have the same support requirements and are permitted to be used in the same locations.

### Electrical Metallic Tubing (EMT)

Electrical metallic tubing (EMT), also commonly called thin-wall, is a listed steel raceway of circular cross section, which is unthreaded, and nominally 10' long. 20' lengths are also available. Covered by Article 358 of the NEC, EMT is available in trade sizes 1/2 through 4. The outside is galvanized for corrosion protection and the inside has an approved corrosion-resistant organic coating.



EMT is installed by use of set-screw or compression-type couplings and connectors. It is permitted to have an integral coupling comprised of an expanded, "belled" shape tube on one end with set screws. EMT with integral couplings is available in trade sizes 1-1/4 through 4.



#### Electrical Code Compliance

EMT is covered by Article 358 of the NEC®.

#### EMT Sizing

EMT is available in trade sizes 1/2 through 4, and 10' and 20' lengths. Some manufacturers also produce EMT in a range of colors for easy system identification.

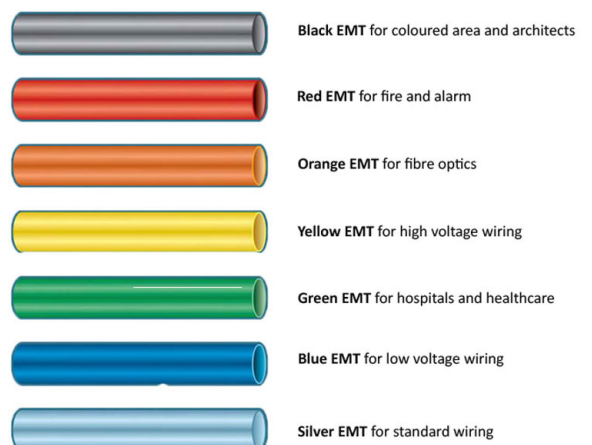

### ***Rigid Aluminum Conduit (RAC)***

Rigid aluminum conduit provides lightweight, nonmagnetic wiring solutions for dry, wet, exposed, concealed or hazardous locations that comply with the National Electric Code® (NEC).



Aluminum Rigid Conduit shall be supported at least every 10 feet and within 3 feet of each outlet box, junction box, cabinet, or fitting, except for straight runs of conduit connected with couplings which may be supported in accordance with NEC Table 344.30 (B)(2), provided such supports prevent transmission of stresses to termination where conduit is deflected between supports.

### ***Flexible Steel Conduit (FSC or Greenfield)***

When you decide to use “Greenfield” on the job you are really dating yourself, so I would just call it “flex”. It was invented in 1902 by Harry Greenfield and Gus Johnson and when it was listed by Sprague Electric Co. it was called “Greenfield flexible steel conduit”.



Today the term “Greenfield” is commonly used for all FMC (flexible metal conduit-NEC Art. 348). FMC is also manufactured in both aluminum and steel.



The NEC defines FMC as “A raceway of circular cross section made of helically wound, formed, interlocked metal strip.”

### ***Liquidtight Flexible Steel Conduit (LFSC)***

Sealtite Flexible Conduit

Liquid Tight Flexible Steel Conduit is designed to hold power, control and communications cables in dry, wet or oily locations.



The conduit is constructed from a zinc coated galvanized low carbon steel strip with a uniform width and thickness.

A rugged flame retardant and moisture, oil and sunlight resistant polyvinyl chloride (PVC) jacket covers the metal conduit.

Other colors available include grey, black, red, orange, yellow and green.

### ***PVC Coated Rigid Steel Conduit***

PVC coated galvanized rigid conduit with urethane interior coating protects conductors from mechanical damage and corrosive attack. Electrical continuity is maintained across assembled joints.





## Plastic Conduits

Rigid PVC pipe, electrical nonmetallic tubing (ENT), and liquid-tight flexible nonmetallic conduit (LFNC) are the most likely plastic conduits to be found in a residential, commercial, and industrial installations.

Because it's approved for direct burial and—if it's a schedule-80 pipe—can be used to meet the NEC's requirement for "protection from physical damage," rigid PVC is run in most new underground service entrances to the electrical meter enclosure.

Sizes range from ½ in. dia. to 3 in. dia. for common residential applications. Rigid PVC is inexpensive; can be worked easily without expensive tools; and can be used in walls, outside in the sun, and underground. Connections are made with PVC glue. Rigid PVC can become brittle in cold weather, so check manufacturers' acceptable temperature ranges.

### *PVC Rigid Conduit*

The Most Common of All Electrical Conduits

PVC is the lightest conduit material and usually the most affordable type of conduit. PVC pipes can vary in thickness depending on the uses and where the PVC will be installed.

The PVC conduit resists moisture and corrosion but the tubing is non-conductive an extra grounding conductor must be passed into each conduit.

PVC conduit has a higher thermal coefficient of expansion allowing the conduit to expand and contract. Installing PVC underground in multiple or parallel run configurations, mutual heating might cause problems on cable performance.

### PVC Conduit: Schedule 40 vs. 80

Schedule 40 PVC conduit is cheaper and has a larger inside diameter, so it's easier to pull wires through it. The plastic on Schedule 80 is thicker, but the conduit has the same outside diameter as 40, so the inside diameter is smaller. Always install Schedule 80 conduit in high-traffic areas or any other areas where it could get damaged, like behind a woodpile. The fittings (such as adapters and turns) are the same for Schedule 40 and 80.



### ***Electrical Non-Metallic Flexible Tubing (ENT)***

ENT, or “Smurf tube” (nicknamed because of its light-blue color), is a corrugated, flexible PVC plastic tubing used mostly for dry interior work or in certain places, such as a basement or crawlspace, where moisture exists on the interior of a building.



ENT is easier to install than rigid PVC, although it and its fittings are about twice the price. However, not all jurisdictions allow for residential wiring with ENT, and there are some places in a house where it cannot be installed—for example, it can't be used for exposed work, and with a few exceptions, it needs to be protected from physical damage. However, it can be encased in concrete and within slabs when the appropriate fittings are used, making it a viable choice for roughing in kitchen islands on a slab.

### ***Fiberglass Conduit***

The demand for fiberglass conduit in the United States alone has been growing significantly over the last two decades and is forecasted to increase further as project owners and engineers seek to serve long-term interests of their stakeholders.



One of the benefits of fiberglass conduit is that it will not melt or weld the wire to the inside of the conduit under fault conditions as can happen with PVC, steel and aluminum conduit.

Total installed longevity, faster installation time, less expensive installation costs, lightweight, are a few reasons why it is advantageous to use fiberglass conduit vs. PVC coated conduit.

### ***Liquidtight Non-Metallic Flexible Tubing (LNT)***

For use in situations that call for a liquid-tight conduit that is able to withstand vibration, movement, oil and corrosives. Perfect for indoor/outdoor lighting, water treatment systems and HVAC equipment.

Easy to install and cuts easily.

Approved for direct burial and in concrete trade sizes 3/8" through 2"





## Other Raceways

Surface Metal Raceways  
Nonmetallic Surface Raceways  
Metal Wireway  
Underfloor Duct  
Trench Duct

## Cable Tray

Steel  
Aluminum  
Fiberglass

## Metal Boxes

Metal boxes are typically used with metal raceway mainly as a place to pull wires, splice wires, and install devices. The types of available boxes and their applications are numerous. For example, a 4-inch square metal box with knockouts (concentric circles that can be removed for installing conduit) is used extensively for installing power devices - receptacles and lighting devices - switches, and as a back box for light fixtures and fire alarm devices. Metal boxes come in a variety of shapes: square, octagon, and round.

Depending on the installation other accessories may be required such as, mudrings (p-ring), extension rings, barhangers, covers, blank plates, connectors, and wire nuts.

Gang is used to describe the number of devices housed inside the box. 1-Gang Box will house one device, a 2-Gang Box will house two devices, etc.

Masonry, weatherproof, utility (handy box), and ceiling fan are just a few of the varieties available.

Pull/Junction Boxes are large enclosures that are used to splice large conductors, as a place to pull wires, and to house electrical controls.

Cast boxes are often used in hazardous locations where ignitable gases, dusts, or fibers are present. Explosion-proof boxes can prevent an arc inside the box from escaping and igniting combustible material. Cast boxes are sometimes referred to as hub boxes because they have threaded hubs for connecting metal conduit.

## Plastic Boxes

Nonmetallic boxes are typically used with nonmetallic sheathed cable or nonmetallic raceways. They come in many different shapes and types depending on the application.

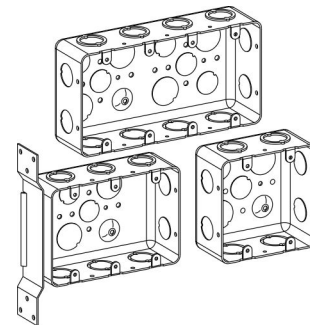
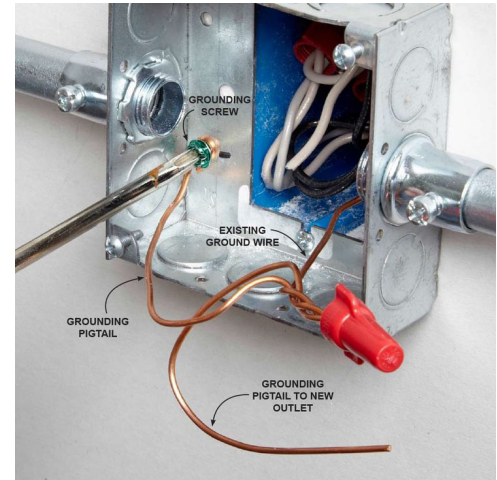
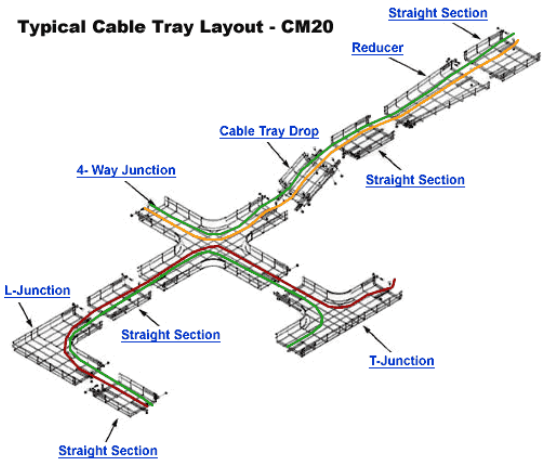

## Section 8: Division 26 - Electrical

### 26 05 19: Low-Voltage Electrical Power Conductors and Cables

#### General Information

- Wire, Cable, Lugs, Terminations, Busway and Bus Duct Pulling cable, including set-up and removing jacks, sheaves and cable pullers
- Testing circuits for continuity only

#### Building Wire

A wire is an electrical conductor made from a conductive material like copper or aluminium that is covered with a protective insulation to prevent contact with other conductors or objects. If the wire is bare it is being used as a grounding wire.

Single-conductor wire can be either solid or stranded. Solid wire consists of a single strand or core of wire that is insulated with non-conductive material. Typically you will find solid core wire in situations where the wire is not designed to be continuously flexed (i.e. your house electrical wiring, wires for breadboards, etc.)

Stranded wire consists of a bundle of small gauge wires compressed and insulated with non-conductive material. Typically you will find stranded wires in situations where the wire needs to be routed through tight spaces or experiences frequent flexing/vibration (i.e. headphone cables, speaker wire, automotive wire, appliance cables, etc.)

The AWG - American Wire Gauge - is used as a standard method denoting wire diameter, measuring the diameter of the conductor (the bare wire) with the insulation removed. AWG is sometimes also known as Brown and Sharpe (B&S) Wire Gauge.

The higher the number - the thinner the wire. Typical household wiring is AWG number 12 or 14. Telephone wire is typical AWG 22, 24, or 26.

<b>3/0 Gauge</b>	<b>200 Amps</b> Service entrance
<b>1/0 Gauge</b>	<b>150 Amps</b> Service entrance and feeder wire
<b>3 Gauge</b>	<b>100 Amps</b> Service entrance and feeder wire
<b>6 Gauge</b>	<b>55 Amps</b> Feeder and large appliance wire
<b>8 Gauge</b>	<b>40 Amps</b> Feeder and large appliance wire
<b>10 Gauge</b>	<b>30 Amps</b> Dryers, appliances, and air conditioning
<b>12 Gauge</b>	<b>20 Amps</b> Appliance, laundry and bathroom circuits
<b>14 Gauge</b>	<b>15 Amps</b> General lighting and receptacle circuits

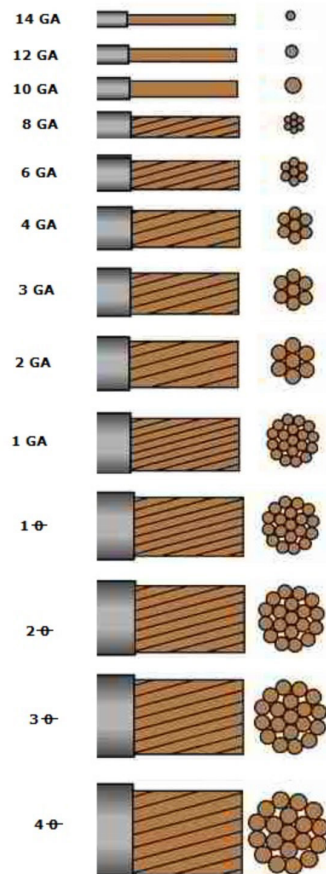

WIRE TYPE	THHN/THWN-2 – Polyvinylchloride (PVC)	XHHW-2 – Cross-Linked Polyethylene (XLPE)
	Wire Insulation	Thermoplastic
Minimum Installation Temp °C	-10°C (14°F)	-40°C ← BEST
Emergency Overload Temp °C	105°C	130°C ← BEST
Maximum Short Circuit Temp °C	150°C	250°C ← BEST
Insulation Resistance after 12 wks (Meg Ω – 1000 ft.)	0.85	105,250 ← BEST

#### THHN Wire

- T Thermoplastic
- HH Hot Hot (90 degrees Celcius)
- N Nylon Outer Covering

#### XHHW-2

- X Cross Linked Polyethylene
- HH Hot Hot (90 degrees Celcius)
- W Wet Locations
- 2 90 degrees wet or dry locations

#### RHW

- R Rubber
- H Hot (75 degrees Celcius)
- W Wet



## Cable

Cable is a group of two or more wires wrapped in a nonmetallic sheath (NM) or an armored or metal clad (AC, MC) protective flexible housing. Cable is both the conductor “wire” and the sheath “conduit” fabricated together. Installation is typically faster than installing conduit “pipe” and conductors “wire” since once installed, no additional labor is required to pull the wires through the housing.

There are many different types of cable available to meet various installation requirements. Indoor, outdoor, and direct burial are just a few options.

The most common cable used in residential installations is Romex®. The Romex® brand of Non-Metallic Building Wire (“NM”) originated in 1922 with its development by the former Rome Wire Company, a predecessor to General Cable Corporation.

### SINGLE-CONDUCTOR WIRES

Solid-core wire



Stranded wire



### MULTICONDUCTOR CABLES

Type NM (nonmetallic sheathed) cable “12-2”

For interior circuits; routed behind walls, ceilings, floors



Type NM (nonmetallic sheathed) cable “14-3”

For interior circuits; contains two hot wires



Large appliance cable

For dedicated 120/140-volt circuits; stranded wires are bendable--but barely

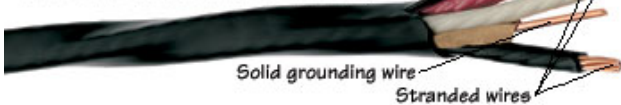

Type MC armored cable

For interior circuits only

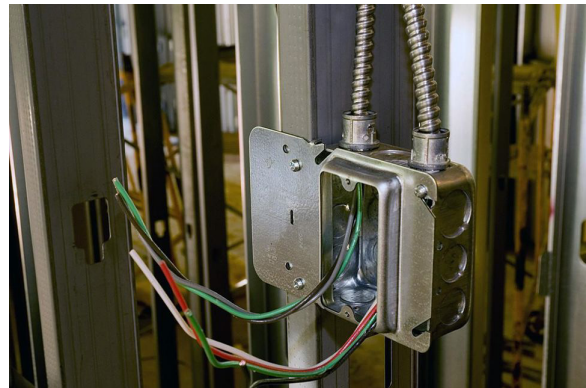
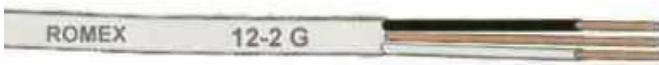

**Section 8: Division 26 - Electrical**  
**26 27 00: Low-Voltage Distribution Equipment**

**General Information**

The labor units in this section include the installation of the wiring device in a box already in place and the termination of copper conductors on the wiring device. The labor units for wiring devices which are factory mounted in enclosures include the installation of the enclosure and the termination of copper conductors. When aluminum conductors are terminated on wiring devices the labor units in this section must be increased.

**Devices**

Device. A unit of an electrical system that carries or controls electric energy as its principal function. NEC 100. The most common example of devices used everyday are switches and receptacles.

Devices are typically selected based on the rated amperage and voltage. Exceeding either of these values can lead to early failure or a potential hazard.

Receptacle outlets are available in a number of options: general-purpose grade, specification (spec) grade, and hospital grade as well as a few others. The National Electrical Manufacturers Association (NEMA) has created standards that receptacles and plugs are built to.

Tamper-resistant and weather-resistant receptacles are designed for specific locations.

GFCI receptacles provide ground-fault circuit interruption. Class A GFCI devices will open the circuit if a ground fault of 4-6 milliamperes or more occurs. GFCI receptacles are less expensive than GFCI circuit breakers. NEC 210.8 lists the locations that are required to have GFCI protection, such as bathroom and kitchen outlets near water.



15A, 120V  
General-Purpose



20A, 120V  
Spec Grade



20A, 120V  
Hospital Grade



20A, 120V  
GFCI

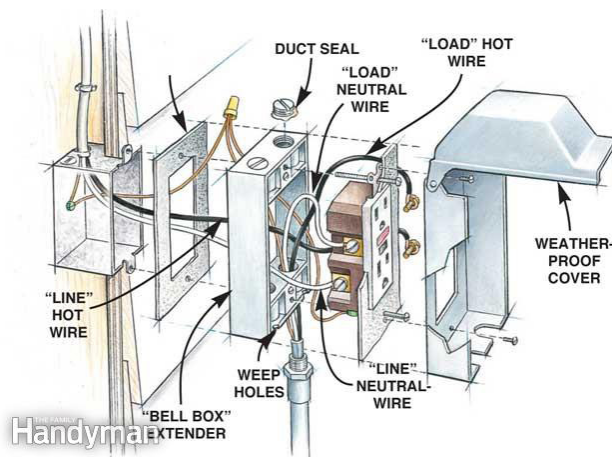

## Switches

Switches open and close electrical circuits, allowing power to flow through lights and appliances. The switch used should match the amperage and voltage for the circuit they serve. Switches designated "CU-AL" are compatible for both copper and aluminum wiring. Be sure to select compatible switches, otherwise, they can present a fire hazard.

The simplest and most common switch is a Single Pole Single Throw Switch (SPST) used frequently for controlling lights. Flipping the switch up completes the circuit, turning lights or appliances on, and flipping it down breaks (opens) the circuit, turning the lights or receptacle off. A single-pole switch has two brass terminal screws on the side that receive the black and white wires of the circuit. (The number of terminal screws identifies the type of switch.) Modern single-pole switches also have a green grounding screw (not shown) that connects to the circuit's ground wire.

A switch that can operate hallway lights from either end of the hallway is called a three-way switch ; it has an extra terminal.

## Occupancy Sensors

- A occupancy sensor automatically turns the lights ON upon detection of motion and turns the lights OFF automatically after the area is vacated
- Occupancy sensors may offer the option to switch the sensor from automatically turning the lights ON to requiring manual button press from the occupant (Manual/Vacancy Mode)

## Vacancy Sensors

- A vacancy sensor requires manual activation of the lights by the occupant, then turns the lights OFF automatically soon after the area is vacated
- A vacancy sensor does not offer an option of automatically turning the lights ON

## Why would I use a Vacancy over an Occupancy Sensor?

- ASHRAE 90.1-2010 and many other codes no longer permit the entire space to be switched on automatically upon occupancy. Automatic ON is only allowed for up to 50% of the controlled load. This requires a sensor that allows for Manual On capability for some or all of the load. For most applications, an occupancy sensor will meet this requirement as long as it allows for dual zone control and manual switch interface.
- New York City Energy Code LL48/2010 states that where occupancy sensors are required, occupancy sensors cannot have an onboard override switch that converts from Manual On to Automatic On functionality. In New York City, vacancy sensors must be used to meet this requirement when used as a stand-alone solution.

Other types of switches:

- 4-way Switch
- Dimmer Switch
- Occupancy Sensor
- Time Clock

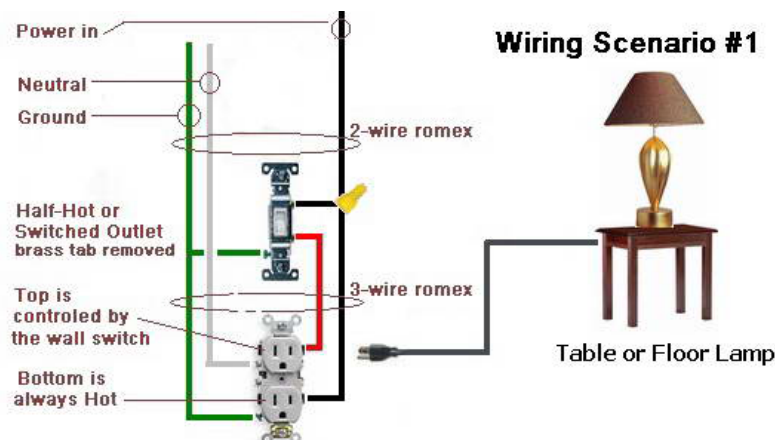



## Section 8: Division 26 - Electrical

**26 51 00: Interior Lighting, 26 52 00: Safety Lighting, 26 54 00: Classified Location Lighting, 26 55 00: Special Purpose Lighting, 26 56 00: Exterior Lighting**

### General Information

- Lighting Fixtures, Poles and Parking Lot Lighting
- Fixture installation
- Power and grounding conductor terminations
- Original installation of lamps and fluorescent tubes, covers and lenses in new lighting fixture installation
- Verification of fixture operation

### Light Fixtures

The appropriate type of light fixture required depends on several factors; where it is installed, purpose for lighting the area, cost, and other considerations. Most lighting designers categorize lighting fixtures into three types: ambient, task, and accent.

Ambient light is fundamental light that brightens up a whole area. A ceiling light fixture is an excellent example of normal lighting. An ambient light fixture may usually be able to handle light bulbs with larger wattages than process or accent accessories.

Task lighting is the lighting you utilize to do tasks, hence the name! A desk lamp is just a excellent example of the task light installation as it can be used especially to do work. Activity lighting tends to be focused on small areas such as for example end tables or desks but does provide a small number of ambient lighting.

Accent lighting is just as the name implies used to provide feature illumination. A light fixture employed for accent lighting won't be bright enough to provide sufficient background or task lighting. This sort of light is used to display artwork or to enhance the atmosphere of any room.

### Fixture Lamp Types

A light fixture or luminaire is a technical and professional term for the electrical fixtures used to hold a lamp—a light bulb—the light source. Common lamps types include: Incandescent (INC), Halogen, Fluorescent (FL), High Intensity Discharge (HID), Light Emitting Diode (LED).



Vintage LED filament light bulb

## Fixture Mounting Methods

### *Troffer*

A troffer is a rectangular or square light fixture that fits into a modular dropped ceiling grid (i.e. 2' by 2' or 2' by 4').

Troffer fixtures have typically been designed to accommodate standard fluorescent lamps (T12, T8, or T5), but are now more commonly designed with integral LED sources. Also referred to as Lay-in fixtures or recessed fluorescent.

### *Surface*

Surface mounted fixtures are usually mounted indoors on ceilings and walls and outdoors on the exterior of buildings.

### *Suspended*

Fixtures can be suspended by pendant, stem, aircraft cable, swivel and canopy, wire, chain, cable, cords, or other similar methods.

### *Recessed*

Flush mounted fixtures are recessed into surfaces such as gypsum board or hard lid ceilings. When installed they are flush with the surface and blend in with the surrounding area. Round recessed lights are called downlights or can lights.

### *High-Bay*

High bay lighting fixtures are designed for applications of 20 feet or more. A wide range of indoor lighting fixtures provide specific light patterns for high bay lighting applications, including maintenance lighting, warehouse lighting, recreation center lighting, hangar lighting and storage lighting.

### *Low-Bay*

Used to light areas with lower ceilings 20 feet or less. Low bay lighting options have diffusers at the bottom of the fixtures. These diffuse the light, cutting down on the harsh reflections that lower ceilings can cause. The result is a more natural, pleasing light in rooms with low ceilings. The applications for this technology are endless, and they are the perfect option for any tight space.

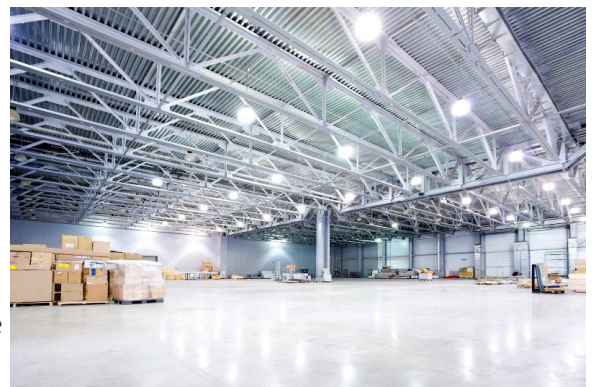



## Section 8: Division 26 - Electrical

**26 12 00: Medium-Voltage Transformers, 26 13 00: Medium-Voltage Switchgear, 26 21 00: Low-Voltage Electrical Service Entrance, 26 22 00: Low-Voltage Transformers, 26 24 00: Switchboards and Panelboards**

### General Information

Switchboards, MCC's, Panelboards and Power Equipment

- Rigging for reasonable lifting and hoisting
- Moving, handling and placing in position, bolting sections/bussing together and factory harness
- wiring for fans, heaters and controls.

Several pages in these sections contain labor units for handling electrical equipment and exclude the labor for conductor terminations. The labor for conductor terminations must be added separately for these items. When labor units in this section do include the conductor terminations, the labor units are based on the minimum sizes of copper conductors allowed by the National Electrical Code.

Material found in these sections was covered earlier in the *Power Distribution* section.



## Electrical Plans

Electrical plans or electrical drawings are created by a design team to illustrate for the electrical installer (electrician) how the electrical systems are to be installed preconstruction. The final set of electrical drawings illustrating how the systems were actually installed are commonly referred to as “as-built drawings”.

## Electrical Construction Drawing Set

A typical set of electrical construction drawings includes the following:

1. Plan for each floor, roof, surrounding site, and other area with electrical installations.
2. Site plan(s) showing incoming utility services and substations; exterior transformers; feeders, trunk lines and backbone cables between buildings; and site lighting.
3. Symbol list and abbreviation list.
4. Schedule(s) of lighting fixtures, mechanical equipment connections, transformers, etc. as appropriate.

## Electrical Symbols











The NEIS NECA 100 - 2006 Symbols for Electrical Construction Drawings publication describes graphic symbols used to represent electrical wiring and equipment on construction drawings. In this publication, the term “electrical” is used to include electrical, electronic, and communications systems covered by the National Electrical Code (NFPA 70). This publication also summarizes recommended drawing practices for electrical construction drawings.

### Symbol Groups (From: NEIS NECA 100 - 2006 Symbols for Electrical Construction Drawings)

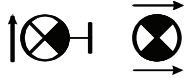
Group	Description
1.0	Wiring Methods
1.1	Raceways—Indicators
1.2	Raceways—Boxes and Busways
2.0	Luminaire (Lighting Fixtures)
2.1	Luminaire Fixtures—Basic Modifiers Mounting
2.2	Luminaire Fixtures—Basic Modifiers Orientation
2.3	Luminaire Fixtures—Basic Modifiers Emergency
2.4	Luminaire Fixtures—Extended Fixtures
3.0	Outlets and Receptacles
4.0	Switches and Sensors
5.0	Motors—Controls
5.1	Motorized & HVAC Equipment
6.0	Security
7.0	Fire Alarm Communications & Panels
7.1	Fire Alarm Indicators
7.2	Fire Alarm Sensors
8.0	Distribution Equipment
9.0	Communications—Teledata
9.1	Communications—Audio/Visual
9.2	Communications—Equipment
10.0	Site Work
11.0	Schematic Fault Circuit Interrupter, Personal Protection
11.1	One-Line Diagram Symbols—Switchboard Meters
11.2	Schematic and One-Line Diagram Symbols—Switches
12.0	Miscellaneous
13.0	Abbreviations
14.0	Nurse Call System

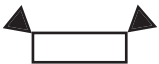

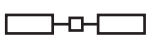

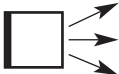

# Example Pages from NEIS NECA 100 - 2006 Symbols for Electrical Construction Drawings

## NECA 100 Symbols for Electrical Construction Drawings



2.0 Luminaire (Lighting Fixtures)		
Number	Preferred Symbol	Description
2.001		Luminaire: (drawn to approximate shape and to scale or large enough for clarity).
2.002		Luminaire strip type (length drawn to scale).
2.003		Fluorescent strip luminaire.
2.004		Fixture—double or single head spotlight.
2.005		Exit luminaire fixture. Arrows and exit face as indicated on drawings (mounting heights to be determined by job specifications).
2.006		Light track. Length as indicated on the drawings, with number of fixtures as indicated on drawings, and as indicated in the fixture schedule.
2.007		Emergency battery remote luminaire heads.
2.008		Emergency battery unit with luminaire heads.
2.009		Single luminaire pole mounted site luminaire fixture.
2.010		Twin luminaire pole mounted site luminaire fixture.
2.011		Roadway luminaire—cobra head.
2.012		Bollard type site luminaire.
2.013		Outdoor wallpack.



**2.1 Luminaire Fixtures—Basic Modifiers Mounting**

Number	Preferred Symbol	Description
2.100		Surface mounted fixture.
		Recessed fixture.
		Wall mounted fixture.
		Suspended, pendant, chain, stem or cable hung fixture.
		Pole mounted with arm.
		Pole mounted on top.
		In-ground or floor mounted. (Box around symbol.)

**2.2 Luminaire Fixtures—Basic Modifiers Orientation**

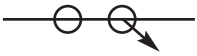



2.200		Accent/directional arrow, with or without tail. (Drawn from photometric center in direction of optics or photometric orientation.)
		Directional aiming line. (Drawn from photometric center and may be extended to actual aiming point if required.)
		Track mounted; length, luminaire types and quantities as shown. (Track length drawn to scale.)

### 2.3 Luminaire Fixtures—Emergency

Number	Preferred Symbol	Description
2.300		Luminaire providing emergency illumination. (Filled in.)

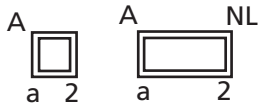
**NOTE:** Modifiers are shown with specific base symbols for clarity. Each modifier can be used with any of the base symbols.

### 2.4 Luminaire Fixtures—Extended Modifiers

2.401		Standard designations for all luminaire fixtures. "A" = Fixture type, refer to fixture schedule "NL" = Unswitched night light "2" = Circuit number "a" = Switch control
2.402		Mounting height.
2.403		Louvers.
2.404		Recessed, emergency fixture.

## Common Electrical Systems

There are many different electrical systems in a typical commercial, residential, or industrial building. Listed below are examples of some of the most common electrical systems.

01 SWITCHGEAR	32 ENERGY MANAGEMENT SYSTEM
02 BUS DUCT/BUS PLUGS	33 PROCESS CONTROL SYSTEM
03 EM. GEN/TR. SW./MG	34 KITCHEN EQUIPMENT
04 FEEDERS	35 MEDICAL EQUIPMENT
05 MOTOR BR. BRANCH/EQUIP. CONNECT	36 HALON SYSTEM
06 FIXTURES	37 LEAK DETECTION
07 LIGHTING BRANCH	38 GROUNDING
08 DEVICES – LIGHTING	39 LIGHTING CONTROL/DIMMING
09 MC CABLE LIGHTING BRANCH	40 LIGHTNING PROTECTION
10 MC DEVICES - LIGHTING	41 CATHODIC PROTECTION
11 LIGHTING SOFT WIRE	42 SITE WORK
12 POWER BRANCH	43 SITE LIGHTING
13 DEVICES – POWER	44 INCOMING SERVICE – POWER
14 MC CABLE POWER BRANCH	45 INCOMING SERVICE – TELEPHONE
15 MC DEVICES - POWER	46 DUCT BANKS AND MANHOLES
16 CABLE TRAY	47 TRAFFIC SIGNAL AND STREET LIGHTING
17 WIREMOLD (SURFACE RACEWAY)	48 REWORK EXISTING
18 RAISED FLOOR POWER DISTRIBUTION	49 DEMOLITION
19 TELEPHONE/DATA CONDUIT	50 TEMPORARY POWER
20 TELEPHONE/DATA CABLE	51 WALKER DUCT
21 FIRE ALARM SYSTEM	70 PV MODULES
22 PUBLIC ADDRESS SYSTEM	71 DC WIRING
23 DR. SECURITY/CARD READER	72 COMBINER BOXES
24 DR. MONITORING.INTRUSION	73 DC DISCONNECTS
25 INTERCOM SYSTEM	74 INVERTERS
26 CCTV	75 AC SWITCHGEAR
27 MATV	76 AC WIRING
28 CLOCK SYSTEM	77 MODULE RACKING
29 NURSE CALL SYSTEM	98 OTHER
30 GAS DETECTION SYSTEM	99 DIRECT JOB COSTS
31 TEMPERATURE CONTROL SYSTEM	

Numbering the systems is often used by an electrical contractor for organizing the electrical estimate into categories or systems.

### System

06 FIXTURES  
07 LIGHTING BRANCH  
08 DEVICES - LIGHTING  
39 LIGHTING CONTROL/DIMMING  
43 SITE LIGHTING

### Estimate Scope of Work

Interior building fixtures (Typically estimated by floor)  
Conduit, hangers, boxes, etc. for the lighting branch circuits  
Lighting devices, such as switches and occupancy sensors  
Lighting control systems / panels  
Parking lot lights, bollards, etc.

## Electrical Construction Drawings - Waste Management Hauling Facility

A typical set of electrical construction drawings will include an electrical symbols legend, lighting fixture schedule, and one-line diagram. The Waste Management Hauling Facility electrical drawings can be found in the Electrical Estimating Activities section.

## Electrical Estimating

### **Steps for Estimating and Bidding Electrical Work**

1. Choose the Right Work to Bid
2. Review the Specifications
3. Review the Drawings
4. Perform a Quantity Takeoff
5. Request Supplier Quotes
6. Create your Estimate
7. Add Overhead and Profit
8. Build your Proposal
9. Double Check Takeoff Quantities & Estimate
10. Submit Bid
11. Review the Results

### **Quantity Takeoff**

The process of counting and measuring items depicted in the electrical drawings such as; light fixtures, receptacles, conduit runs, panels and switchgear.

### **Quantity Takeoff Process**

Study the drawings to understand the scope of work and how the items you are counting, or measuring are installed.

For example, conduit in a slab versus conduit in the wall or fastened to a steel beam are installed differently.



Conduit Installed in a Slab

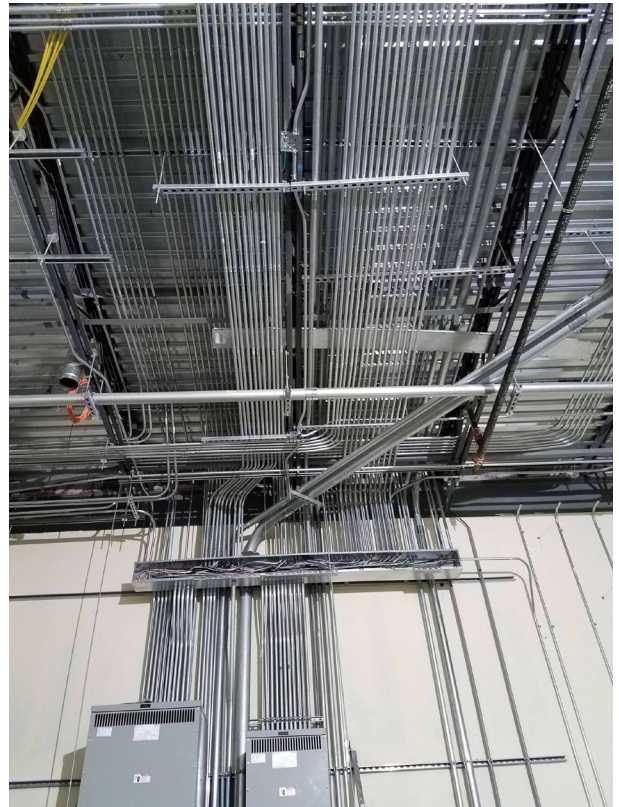

Conduit Installed Along Wall and Ceiling



Conduit in a slab can often use the shortest run from point A to point B and runs under the slab do not have to be installed parallel or orthogonal to the building walls or framing.

Conduit runs in a slab are “stubbed-Up” to the device, panel, box, or location it is being connected to. The requirement for the stub-ups is given in the specifications.

PVC conduits often must be stubbed-up with rigid elbows.



PVC Conduit Stubbed-Up with GRS Elbows



PVC 90's? Aren't you concerned about your jet line/rope cutting through them when you pull the wires? We always use rigid 90's underground.

## Typical Specification

### 3.03 Workmanship:

- A. All work shall be executed in code compliance, when completed. All exposed conduit, line, boxes, and fittings shall be installed parallel or perpendicular with principal structural members of the buildings in

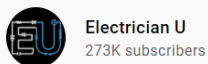

[Working With EMT - ELECTRICAL METALLIC TUBING and What Electricians Should Know](#)

The isometric drawing below (not to scale) illustrates the horizontal and vertical installation of conduit installed in a ceiling (Lighting Branch) and in a slab (Power Branch).

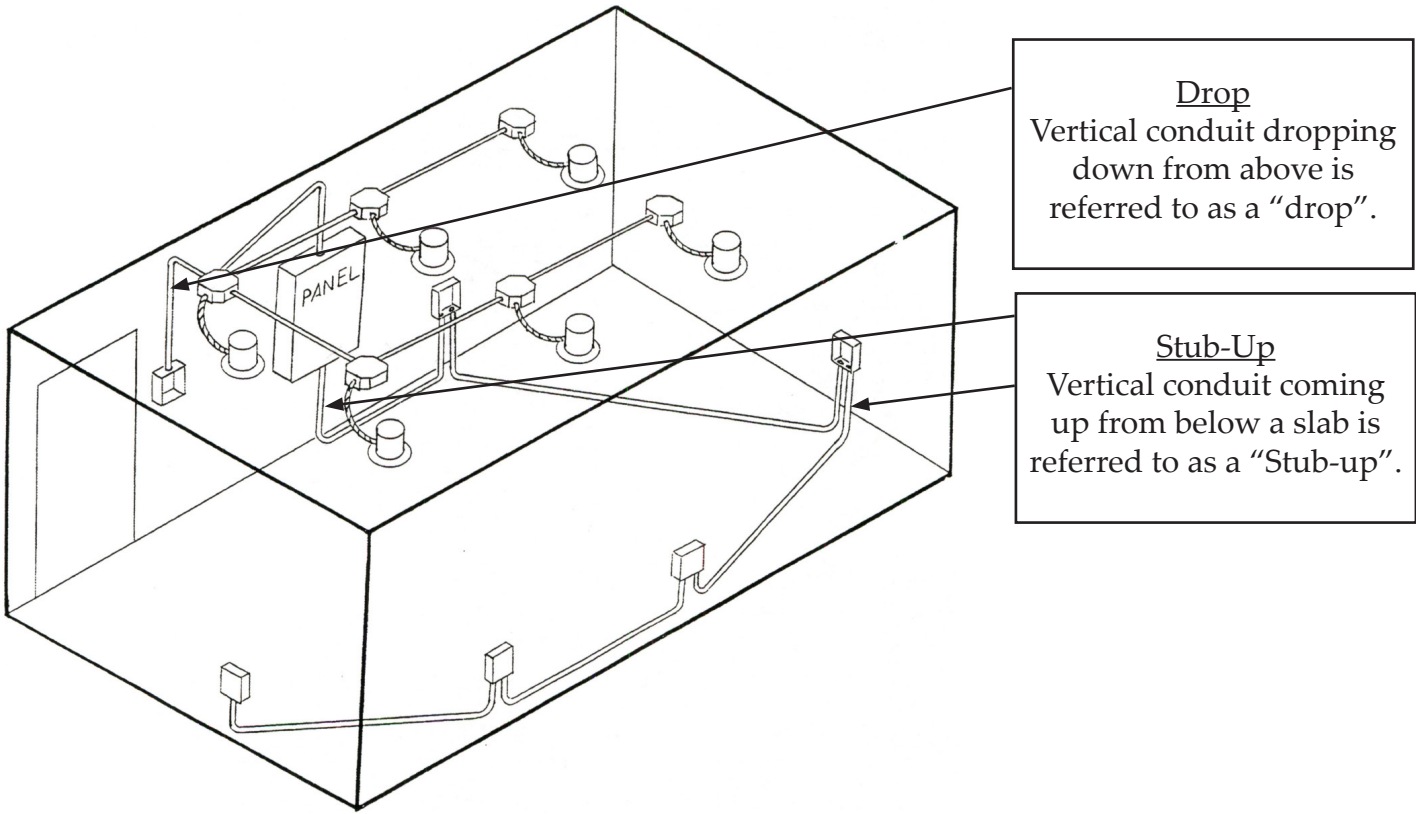

Drop  
Vertical conduit dropping down from above is referred to as a "drop".

Stub-Up  
Vertical conduit coming up from below a slab is referred to as a "Stub-up".

Plan View

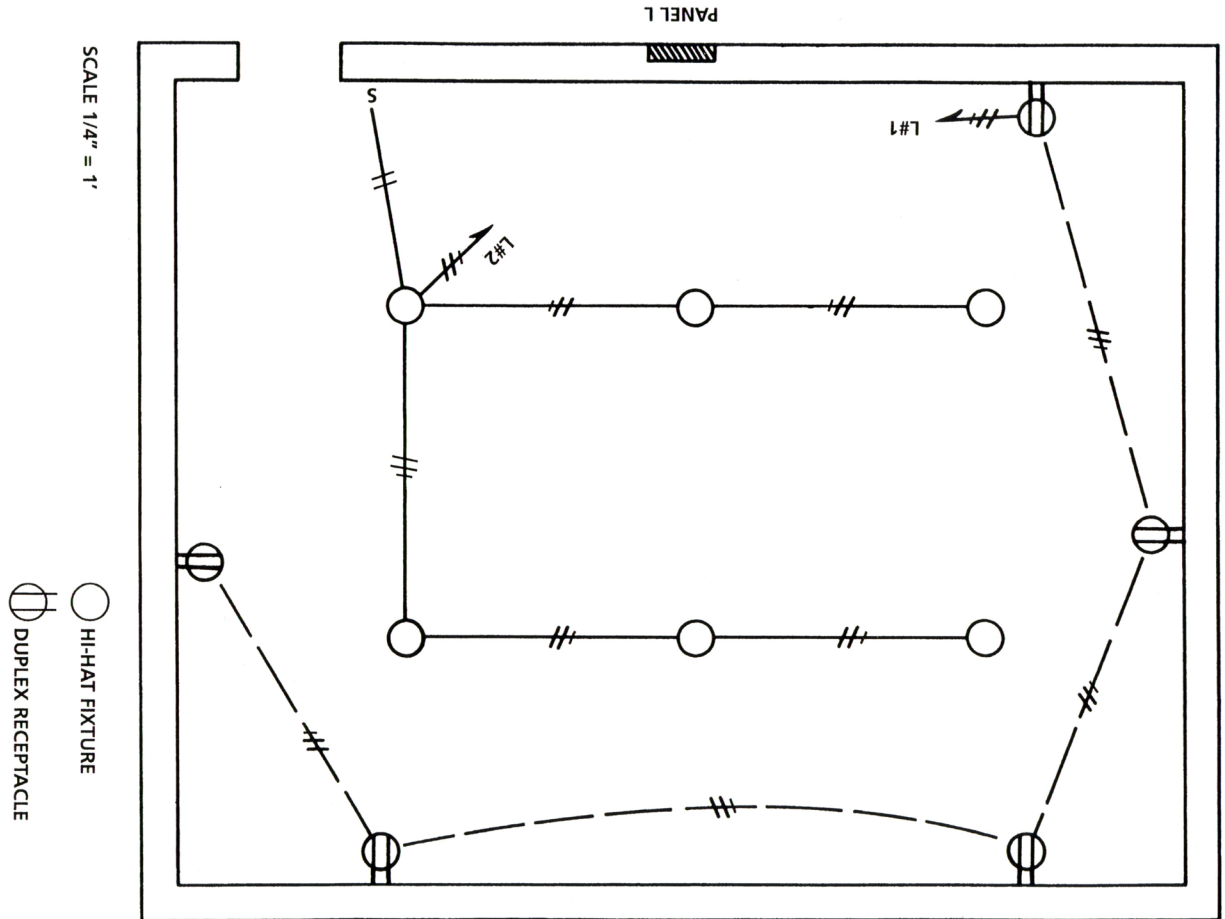

# Takeoff Sheet

Totals of each item to be installed are organized and recorded in a takeoff sheet.

Example: Takeoff Sheet for Light Fixtures (Waste Management Hauling Facility)



## TAKE OFF SHEET

JOB Waste Management Hauling Facility  
ESTIMATED BY LHG

SYS 06 FIXTURES  
08 Devices - Lighting  
SHEET      OF       
DATE     

SYMBOL	2x4 LED LAY-IN	2x2 LED LAY-IN	11" Linear High Bay Chain	LED Canopy	LED WALL PACK	8 FT LED Linear Shop Light	6" LED DOWN LIGHT REC	LED EM LIGHT W/BATT	LED EXIT W/EM	\$	\$	\$	\$	\$	\$	\$	\$	\$	\$	\$	\$	
DESCRIPTION										20A SP SW	20A SP SW	20A 3-WAY SW	20A 3-WAY SW	20A 5W SW	20A 5W 2G							
EI LIGHTING PLAN	64	2	26	9	16	14	10	4	13	23	3	6	2	1								

Before counting or measuring items the first step is to prepare a takeoff sheet for the system to be counted such as, light fixtures, or measured, such as Branch Lighting. Then, using the corresponding drawing for the system to be counted or measured, count or measure all items for each drawing where they are shown to be installed and record on the takeoff sheet. Continue until all those items for each drawing where they are shown are counted before moving to the next item. If you find something you missed earlier, immediately count it and adjust your previously noted quantity. Most companies have a Takeoff Color Code for marking the items counted on the plans.

For example, color all light fixtures with a yellow highlighter and emergency fixtures with an orange highlighter. Lighting devices (switches, etc.) color with a blue highlighter.

Example: Colored Lighting Fixture Plan

**ELECTRICAL NOTES**

- BY NEW SCALE DRAWINGS REFER TO ARCHITECTURAL DRAWINGS AND EXISTING CEILING PLAN FOR EXACT LOCATIONS OF ROOMS, STUDIOS AND CEILING SERVICES. MAKE SURE TO CHECK DRAWINGS FIRST.
- MARK TO STRUCTURE BEFORE CUTTING AND PATCHING FOR WORK. DESIGNER WILL BE RESPONSIBLE TO EXISTING CONDITIONS AT CONTRACTOR'S EXPENSE.
- ALL ELECTRICAL WORK SHALL BE INSTALLED IN ACCORDANCE WITH THE NATIONAL ELECTRICAL CODE IN FORCE AT TIME OF BID AND ALL GOVERNING LOCAL CODES OR ORDINANCES.
- ALL MATERIALS SHALL BE NEW AND SHALL BE UNDERWRITER'S LABORATORY APPROVED.
- COORDINATE ALL CIRCUITING REQUIREMENTS WITH OTHER DISCIPLINES AND ALL TESTING AND SETTING FOR BEST PRACTICES.
- UNLESS OTHERWISE NOTED IN THE PLANS, ALL WALL-MOUNTED SWITCHES SHALL BE MOUNTED TO ADJACENT WALLS. WALL-MOUNTED SWITCHES SHALL BE MOUNTED TO ADJACENT WALLS. UNLESS OTHERWISE NOTED IN THE DRAWINGS.
- ALL LINES SHALL BE INSTALLED IN EMPTY TELEPHONE CONDUIT AND RECAPED TO CONDUIT SHALL BE 3/4" NOMINAL AND TERMINATED ABOVE CEILING WITH INSULATED BUSHING.
- ALL CONDUITS SHALL BE COVERED AND COLORED CODED IN ACCORDANCE WITH NEC UNLESS SPECIFICALLY INDICATED OTHERWISE.
- EXTERIOR LIGHTING CONDUITS SHALL BE NOMINAL 3/4" AVG.
- FINISHES AND INSTALL "GROUNDING" IN ACCORDANCE WITH NEC ARTICLE 250.

**ELECTRICAL SYMBOLS LEGEND**

○	RECESSED SWAPLIGHT	○	DOOR SILENCER	○	DOOR SILENCER
□	RECESSED WALLWASH	○	FLOOR OR CEILING MOUNTED RECEPTACLE	○	GROUNDING POINT
□	RECESSED 2" x 4" LIGHTING FIXTURE	○	CONDUIT BULLET	○	PLUMB MOUNTED TELEPHONE BULLET
□	FLOURESCENT SHOP LIGHT	○	WALL MOUNTED TELEPHONE BULLET	○	WALL MOUNTED TELEPHONE BULLET, PROVIDE STRONGMOUNT BRACKET
□	8 FT LINEAR SHOP LIGHT	○	RECESSED CANOPY LIGHT	○	RECESSED CANOPY LIGHT
□	6" LED DOWN LIGHT REC	○	EMERGENCY LIGHT W/BATTERY PACK	○	EMERGENCY LIGHT W/BATTERY PACK
□	LED CANOPY	○	EXIT SIGN	○	EXIT SIGN
□	LED WALL PACK	○	EMERGENCY LIGHT W/BATTERY PACK	○	EMERGENCY LIGHT W/BATTERY PACK
□	LED EXIT W/EM	○	EMERGENCY LIGHT W/BATTERY PACK	○	EMERGENCY LIGHT W/BATTERY PACK
□	LED EXIT W/EM	○	EMERGENCY LIGHT W/BATTERY PACK	○	EMERGENCY LIGHT W/BATTERY PACK

**LIGHTING FIXTURE SCHEDULE**

SYMBOL	DESCRIPTION	LAMPS	MODEL
□	2" x 4" LAY-IN LED TROFFER	LED	LSI LPE24-HO-NV-UE
□	2" x 2" LAY-IN LED TROFFER	LED	LSI LPE24-HO-NV-UE
□	LINEAR HIGH BAY	LED	LSI LMB11-LED-SLS-SUNV-60-BLDS
□	LED CANOPY LIGHTS	LED	LSI XSP5-S-LED-SS-CN-120-DWT-CFL
□	WALL PACK	LED	LSI TMWP-600-60K-62
□	LINEAR FLOURESCENT SHOP LIGHT	LED	LSI LCO3-S-LED-60-90-UNV
□	RECESSED CAN LIGHTS	LED	LSI LCO3-S-LED-40-90-UE-TR88-6F-HA2-WH
□	EMERGENCY LIGHT W/BATTERY PACK	LED	LSI LTEM-WH2
□	EXIT SIGN	LED	LSI LPRX-A-U-WH-D11-R

**RM3 Engineering**  
2302 Peachtree Street  
Peachtree, Georgia  
30094  
770 599 0862  
770 594 0862

WASTE MANAGEMENT HAULING FACILITY  
HIGHWAY 17  
HARDEEVILLE, SC

## Process for Counting Fixtures

The basic process for the counting Fixtures is to choose the Fixture type to be counted. Using the yellow highlighter, color the fixture symbol on the plan and "click" the hand tally (clicker). Continue coloring and clicking until all fixtures of that type have been counted. Record the number in the corresponding location on the takeoff sheet. Repeat for another type of fixture.

## Take Off Color Code

To have a consistent process for estimating the scope of work for the different electrical systems and indicating on plans that the components have been accounted for a take off color code is helpful.

The take off color code below shows the different color highlighters used for each system. For example, use the pink highlighter to count power devices, such as, receptacles.

Colored pencils are used for coloring conduits that have been measured, such as, Lighting Branch, Power Branch, Fire Alarm Branch, and Feeders.



### TAKE-OFF COLOR CODES

SYSTEM	HIGHLIGHTER			
LIGHTING FIXTURES	YELLOW			
EMERGENCY FIXTURES	ORANGE			
<b>DEVICES</b>				
POWER	PINK			
LIGHTING	BLUE			
TELE/DATA	GREEN			
FIRE ALARM	RED PENCIL			
<b>DISTRIBUTION EQUIP</b>				
REGULAR POWER	BLUE			
EMERGENCY POWER	ORANGE			
<b>DUCTS AND TRAYS</b>	GREEN			
<b>MOTORS &amp; CONN</b>	BLUE			
<b>GROUNDING</b>	GREEN			
<b>MISC SYSTEMS</b>	DRK BLUE			
	DARK BLUE OR ANY UNUSED COLOR WITH NOTATION ON DRAWING			
	<b>PENCIL COLORS</b>			
<b>FEEDERS</b>	EMT	NM Cable	PVC	GRC/IMC
<b>BRANCH</b>	RED	MC CABLE	GREEN	BROWN
<b>EXISTING / FBO</b>	PURPLE			

**REMINDER: If it is not colored, then it is not counted!**





**Chris Lee**

Chris Lee has an extensive background in preconstruction management as a former specialty contractor and business owner. As the Chief Estimator at Esticom, he has helped thousands of specialty contractors digitize their preconstruction process to increase revenue and profitability while decreasing unnecessary overhead.

### **How to estimate electrical work - basic steps to do it right**

In the world of electrical contracting, you must estimate and submit bids to win projects and stay in business. This means bidding low enough to win against many competing electrical contractors, while high enough to cover all the project costs like labor, material, equipment rentals, subcontractors, and indirect cost or otherwise known as overhead required to run your business. And do not forget including enough profit for taking on the risk and of course growing the business. In the steps below, we have outlined a proven electrical estimating system to help you get started.

1. Choose the Right Work to Bid
2. Review the Specifications
3. Review the Drawings
4. Perform a Quantity Takeoff
5. Request Supplier Quotes
6. Create your Estimate
7. Add Overhead and Profit
8. Build your Proposal
9. Double Check Takeoff Quantities & Estimate
10. Submit Bid
11. Review the Results

### **11 Steps to Estimating Electrical Work**

1. **Choose the Right Work to Bid** - The first step in the electrical estimating process is selecting the right type of work to bid. You should avoid bidding electrical projects where you have limited experience and are more likely to make mistakes during the estimating process and project execution should you win the electrical construction project. There is a learning curve for electrical estimators and your field staff when taking on any new type of work that can eat into your profit.
2. **Review the Specifications** - Thoroughly review the Division 01 general specifications in addition to the Division 26 specifications and pay close attention to contractor qualifications, payment terms, bonding capacity, insurance requirements and make sure you can meet the qualifications and live with the legal language should you win the construction project. When you are finished with the general specifications, it is time to move onto the Division 26 specifications and make a note of the material grade, installation methodologies and responsibilities of costs (who provides fire alarm, communications, etc.) Generally, the specs will determine the quality of materials while the drawings determine quantities. It is important to highlight anything out of the ordinary and make sure you include these items in your bid. I have seen many contractors take a black eye on an otherwise profitable project because they bid a less expensive material grade only to find during the project execution that it was significantly more expensive. If you intend to offer an alternate option, make sure it is approved first and in writing because they will hold you to the specified material grades.
3. **Review the Drawings** - Look over the drawings at a high level to get an idea of the full scope of work. You should review the architectural in addition to the electrical drawings to understand working heights and elevations that will affect labor costs, material pricing and equipment requirements. Once you understand the general construction (think birds eye view of the project) it is time to review the Division 26 drawings taking note of any technical details that are depicted and watch for any discrepancies between the drawings and specifications and write this down.

4. **Perform a Quantity Takeoff** - Pull out your highlighters, scale master or your favorite takeoff software to begin the process of counting and measuring items depicted in the electrical drawings like light fixtures, receptacles, conduit runs, panels and gear. Start with one item (we suggest light fixtures) and count all items sheet by sheet keeping totals per sheet before moving to the next item. If you find something you missed earlier, immediately count it and adjust your previously noted quantity. Now total your quantities for each sheet and move to a quantity takeoff sheet, example excel sheet below. Note: Are you responsible for HVAC hookups or any low voltage?
5. **Request Supplier Quotes** - One of the reasons we suggest getting your lighting counts first is to speed up receiving a quote for these items because they are generally quoted independently of the rest of your materials. A couple things to note, do not worry about getting the specifics on the light fixtures, rather note the designations used to identify the fixtures on the plans i.e. A1, B1, C1, etc. The lighting firm will reference the lighting schedule and look up the item details and provide a lump sum quote. It is in your best interest to build a relationship with your local lighting firms to ensure you are getting competitive pricing in a timely manner.
6. **Create your Estimate** - Now that you have the quantities laid out, you will need to determine the unit cost for each item. To accomplish this, you need to determine the material and labor costs associated with each task and extend those out by the task quantity. Determining the material cost is simple, a quick call to your supplier or pricing service can give you this data, but the labor cost requires that you know how long it takes to install the material. This requires past production history and experience, or if you do not have past production history and limited field experience we suggest purchasing NECA's Manual of Labor Units to use as a guide. Once the labor unit is determined you will multiply that by the burdened labor cost to determine the labor cost for the task. See the simple excel example quantity takeoff sheet below that includes material and labor costs per task and the totals summarized. Now you will want to summarize the total material cost and total labor hours for all the items, and you'll multiply the labor hours by your fully burdened hourly labor cost to get your total labor cost for the task. Add these two numbers together to determine your total direct costs for the project and the basis for your estimate. Keep in mind, you will need to add line items for any other direct costs required for the installation like equipment rentals or subcontractors.
7. **Add Overhead and Profit** - Now that we have our estimated job cost (direct costs) we need to add profit and overhead to those costs to arrive at our sales price. While profit is self-explanatory, overhead is not and is the total of all the other indirect expenses that are required to run your business including your office lease, estimating, sales, marketing, bookkeepers, and other expenses that must be paid to keep your business operating smoothly. Like profit, overhead is a percentage that you add to the project costs to land at your sales price. Small contractors commonly believe they do not have overhead and shouldn't charge for it and this is not correct. You are leaving money on the table and it's in your best interest to figure out the overhead required to run your small business with an accountant that specializes in construction.
8. **Build your Proposal** - Now that we have our sales price, we need to create a proposal that details what is included in our bid in clear and concise terms. We suggest using similar language to what was used in the project specifications and drawings. This makes it easier for the General Contractor reviewing your proposal to ensure you have covered everything and that nothing major is missing and he can therefore trust your price. Electrical contractors provide lump sum bids. This means you provide a fixed fee to cover everything outlined in your bid. This is where it is important to clarify anything that you have included or excluded to avoid any confusion once the project is awarded. [Free Electrical Proposal Template Here](#)
9. **Double Check Takeoff Quantities & Estimate** - It is always a good idea to get a second set of eyes from your estimating team to review your work prior to submitting your bid to make sure you have not missed anything. This review should involve a counterpart taking off the project's major systems and ensuring that nothing was missed during the original takeoff. We suggest keeping a bid log (simple excel spreadsheet) that shows recent and successfully completed projects by type and size with the price per sq ft listed for reference. While you should never bid projects this way, you can compare a previously completed project against your current project

to see if there is a large variance in price. If there is a big delta, it is worth looking into to figure out why. Note: you can use this log to help with preliminary budget numbers.

10. **Submit Bid** - Once you have double checked your work it is time to submit your bid. Today, everyone submits bids electronically either through the bid site that they received the bid or via email. We suggest that you read the Division 01 specifications again and looking for any bid instructions and follow them to a tee.
11. **Review the Results** - In the beginning it can be tough to determine where you are in the mix compared to other electrical contractors bidding the same work. Remember, General Contractors go with numbers from vendors they trust, potentially years of experience working together, more than the low number, so it might take a couple bids to gain a General Contractors trust. When you lose a project, it is always a good idea to ask the General Contractor how you stack up against the competition, sometimes they will send you the bid tabs with your competitors' numbers and other times they will tell you that you are high or too low for comfort. Unless it is a public bid, they are not required to provide this information, but if you ask in a respectful manner you will receive feedback, and this will help you with adjusting on future bids. Note: It is a good idea to request bid tabs on awarded projects as well to see if you are leaving money on the table by bidding too low.

### **How to Estimate Electrical Work More Easily and Accurately**

If you are thinking that estimating seems like a lot of work, you are right. Electrical estimating requires a serious time commitment, and this goes up significantly if you do not have an electrical estimating system in place. Electrical estimating software provides you with an easier way to get your work done using a prebuilt system and methodology. Good electrical estimating software gives you on screen takeoff, estimating and quoting all in a single package with features like auto-count, a full electrical labor and material database and a way to track your bids. If you are new to electrical estimating, this can provide a framework to get you started and generally electrical contractors see a 2-3x increase in speed over manually estimating projects with paper plans and excel. Usually, it is less expensive than the cost of printing out plans. With the advent of cloud-computing, you now have access to several web-based applications like Esticom that allow you to estimate projects on day one without any heavy upfront costs, set up or implementation. We have a free 14-day evaluation giving you access to the same tools big companies have and it will not cost you a penny to get started. Visit <https://www.esticom.com/electrical-estimating/> today.